

Field Quality in Accelerator Magnet

Ramesh Gupta
BNL

**Note: A significant portion of this talk
was given in non-electronic format**

Incomplete Talk

Sorry Plastic Slides Not-included

Why field Quality is important?

- Influences the performance and cost of the machine
 - At injection: **Main dipoles - large number** - impact performance, magnet aperture and hence the machine cost.
 - At storage: **Insertion quadrupoles - small number** - determine luminosity performance.
 - Corrector magnets + associated system - ease of operation and overall machine cost.
 - Tolerances in parts and manufacturing - translates in to cost.

A proper understanding is important for reducing cost while assuring field quality:

1. Conventional Wisdom: Reduction in random errors is due to smaller variation in cable thickness
 - NOT so. Will be shown based on the theoretical arguments & experimental data.
 2. Conventional Wisdom: Need 1 mil (25 micron) tolerances at most places
 - Experimental Results and Analysis: NOT so. Such realization may reduce tolerance specifications of certain parts - cost savings while maintaining a good field quality.
- A bonus from field quality (used extensively during RHIC magnet production)
 - Field Quality as a tool to monitor production. Powerful, rapid feedback to manufacturer.

Sources of Field Errors

- Magnetic Measurements
 - Both systematic and random. However, the advances in measurements system means that they don't limit the field quality performance.
- Magnetic Design
 - Primarily systematic
- Magnet Construction (tooling, parts & manufacturing)
 - Both systematic and random

A good design will not only produce good field quality magnets on paper but would also anticipate deviations in parts during production and be flexible enough to accommodate them to produce good field quality magnets despite those errors.

Remember: The production can not stop just because a part is “a bit out of tolerance”!

Impact of Cable Thickness on Field Quality

Common perception:

Has major impact on field errors, in particular on the random harmonics.

Basic Analysis:

A thicker cable makes bigger coils, as measured outside the magnet (though coil size can be controlled by adjusting curing pressure).

However, inside the magnet, the collars determine the coil geometry.

Cable thickness has a significant impact on the pre-stress on coils.

But to a first order, it does not have a major impact on field errors for a reasonable deviations in insulated cable thickness (the pre-stress variation will become a bigger issue before the harmonics).

Rapid variations in cable thickness are averaged out over a large number of turns and over the length of magnet.

The location of midplane has a major impact on field quality.

Though the overall cavity is well defined by collars, the location of coil midplane is not. It is determined by the relative size of upper and lower coils. If they are matched, the midplane will be OK.

Something other than the cable is more critical to harmonics.

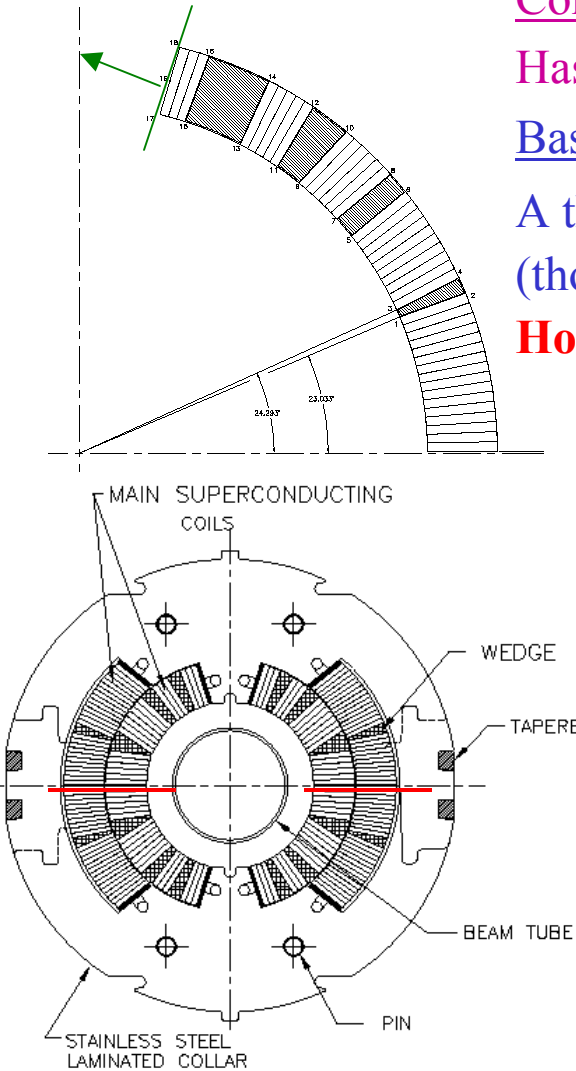

Results from Present Day Magnets (Real Magnets)

What has a major impact on random field errors? Is it cable thickness or some thing else?

Note: NO computer calculations and direct experimental correlation has shown that cable thickness is the major cause of reduction in random field errors in modern magnets.

It is just a common perception, NO proof!

How to disprove something that is not proved.

Scientific Method

Make a large amount of “bad cable” and make many magnets (for statistics). Compare results with similar magnets made with good cable.

Interesting, scientific but not practical.

Alternate Method:

Examine measurements. Find correlation.

Determine what has the pre-dominant effect.

Is it cable thickness or some thing else?

Example 1:

Compare RHIC 80 mm and 100 mm aperture dipoles. Both used same cable and similar designs.

Conventional Wisdom: Smaller random errors in 100 mm.

Reality: NOT so. Bigger in larger aperture dipoles. Why?

Results of investigations: The coils were matched based on the size measured when made/cured. Coils grew in time. Correlation found.

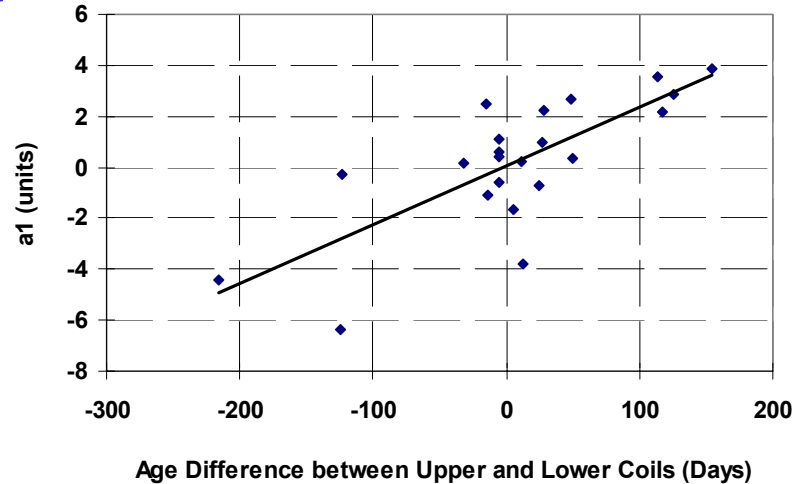

Overall control on coil rather than just cable thickness is more important.
Kapton insulation plays a major role in assuring a uniform coil production.

Results from Present Day Magnets (Real Magnets)

What has a major impact on random field errors?
Is it cable thickness or some thing else?

Example 2:

During RHIC main dipole productions, the axial variation of harmonic became relatively large.

Quantity Selected is Show Harmonic : a (4)

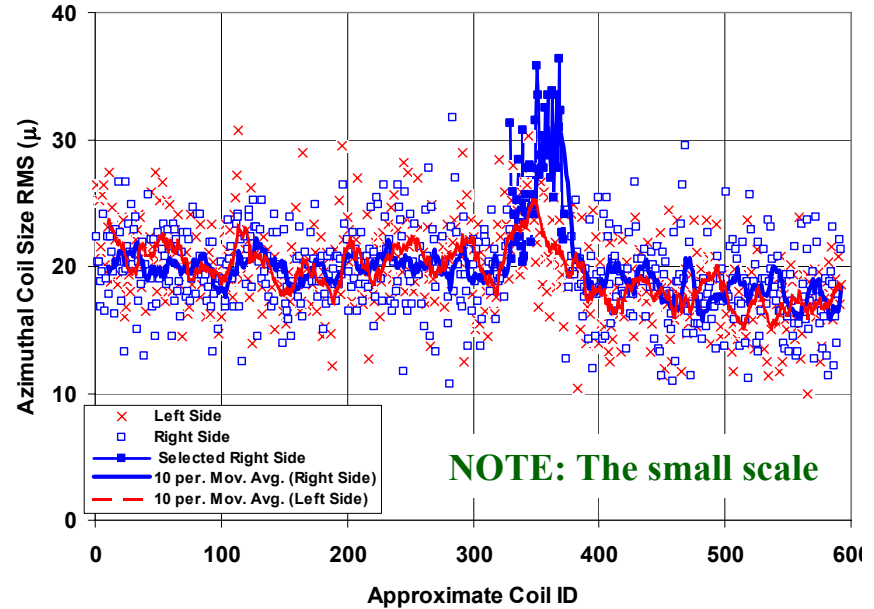
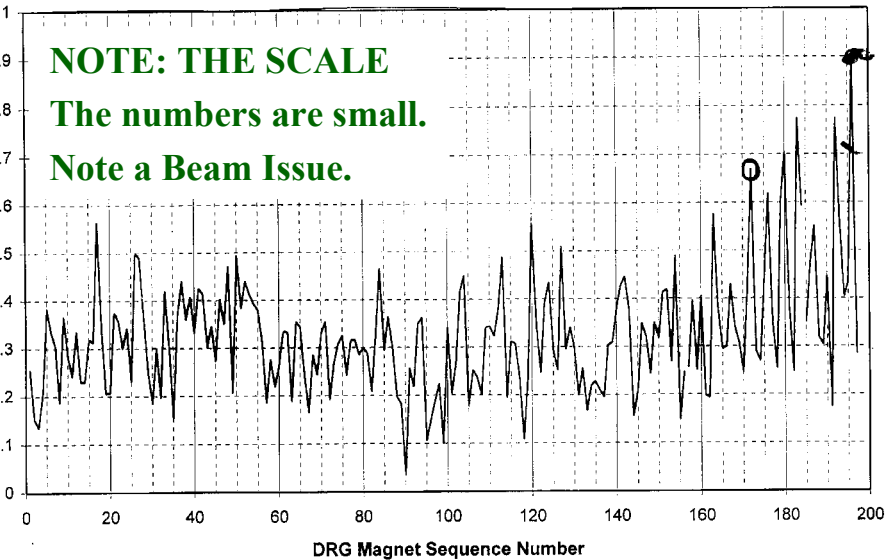

Cable thickness didn't change but the cured coil size changed and harmonics changed due to small human error which are always possible. Stay Vigilant.

Theoretical argument and above observations indicate that a careful control of coil manufacturing is critical for the reduction in RMS field errors.

A SIDE NOTE: The power of "Harmonic Analysis" in monitoring magnet production.

An investigation, led by field error analysis, found a change in coil size in a small section was caused by a small dirt (a few mil) in curing press. Curing press cleaned, problem solved.

Conventional Wisdom: Increasing Aperture Reduces Standard Deviation at 2/3 of the Coil Radius.

Warm Harmonic Measurements in 2 types (apertures) of RHIC Quadrupoles:

80 mm aperture ARC Quads (25 mm reference radius)

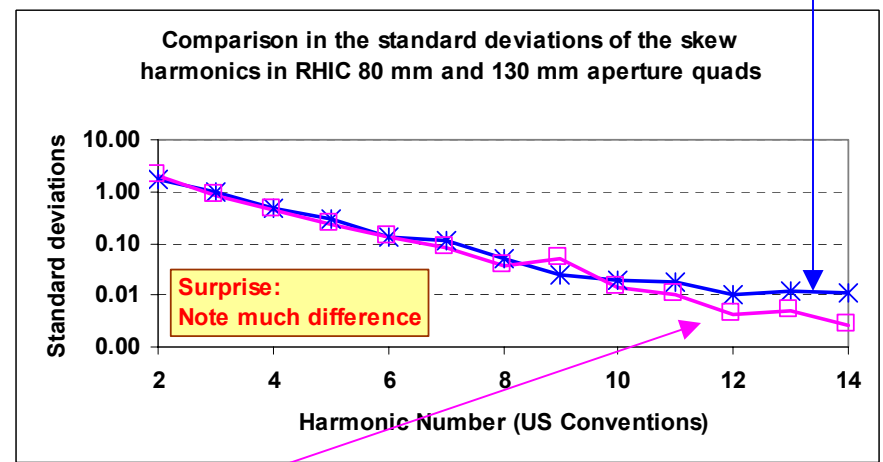
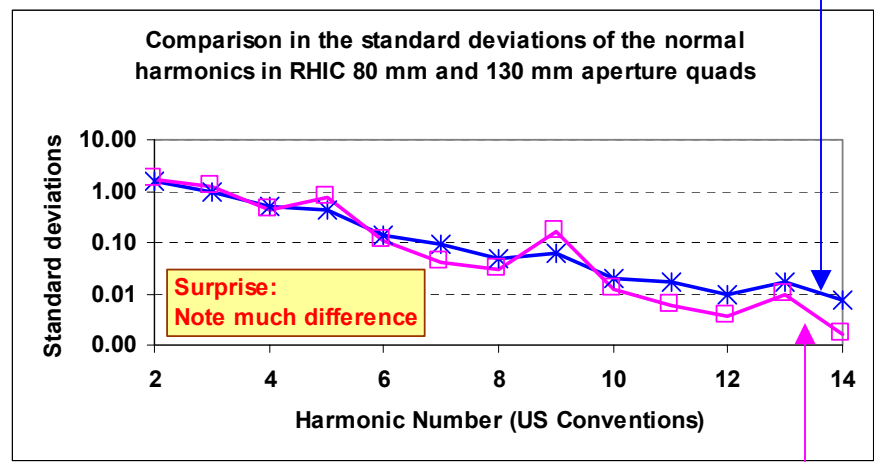

Normal Harmonics

Skew Harmonics

130 mm aperture IR Quads (40 mm reference radius)

Influence of magnet components on field errors
(From: R. Gupta, LHC Collective Effects Workshop,
Montreux, 1995. Published in Particle Accelerators)

Cable and Insulation size have a major impact on coil size and hence pre-stress on the coil in the magnet. They don't influence odd b_n 's and even a_n 's and the influence on odd a_n 's can be made negligible if the azimuthal coil size between the upper and lower halves is matched to $25\mu m$. Unless the variation in cable or insulation thickness is so large that the change in pre-stress on the coil is unacceptable, the influence on even b_n 's is also negligible.

Other Components primarily influence only the allowed harmonics as long as a large quantity of them is used in the magnet. Non-allowed harmonics may be generated if the quantity is small or the mechanical design prevents randomizing in a 4-fold dipole symmetry.

Coil Curing Tooling generates only skew harmonics because of the way coils are installed in a dipole magnet. A difference between left and right side of the coil size or curing conditions generates even a_n 's and an average variation generates odd a_n 's. The influence of the coil curing press on harmonics may be significant (both on RMS and systematic) if it is not stable or uniform.

Coil Collaring Tooling creates primarily odd b_n 's in a horizontally split design and odd a_n 's in a vertically split design. A significant variation in the collaring process may also create even b_n 's. In a reasonably well constructed collaring press, it should have only a small impact on harmonics.

Field Quality in SSC Magnets (Lab built prototype dipoles)

Note:
A general improvement by a factor of 3-10.

Expected and Measured Harmonics at 2 T in BNL-built and FNAL-built SSC 50 mm Aperture Dipoles

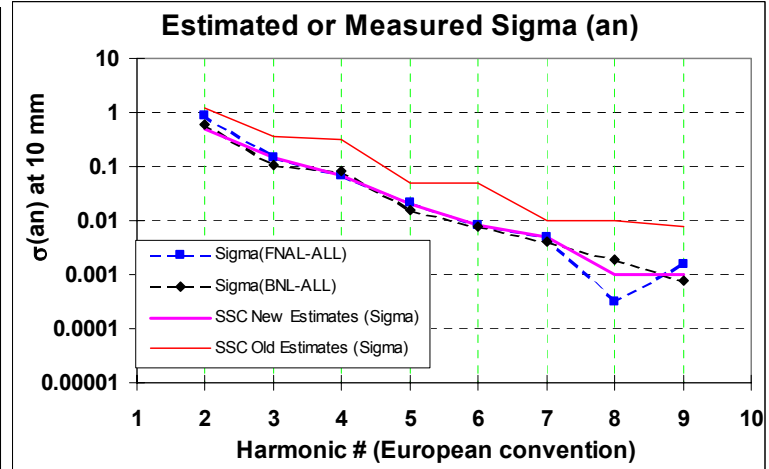
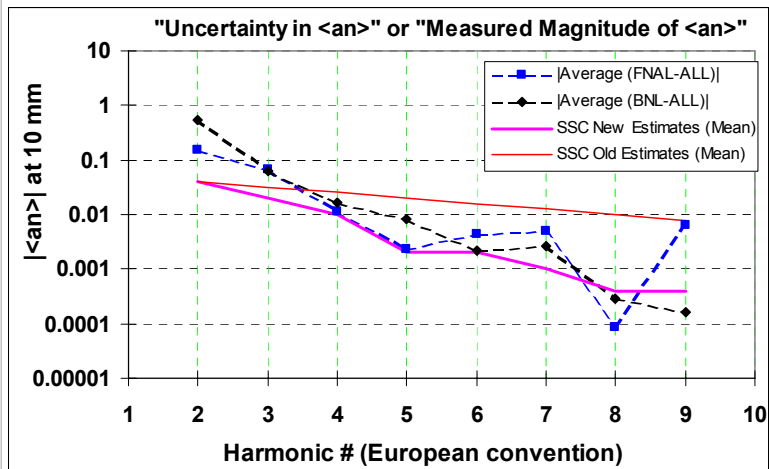
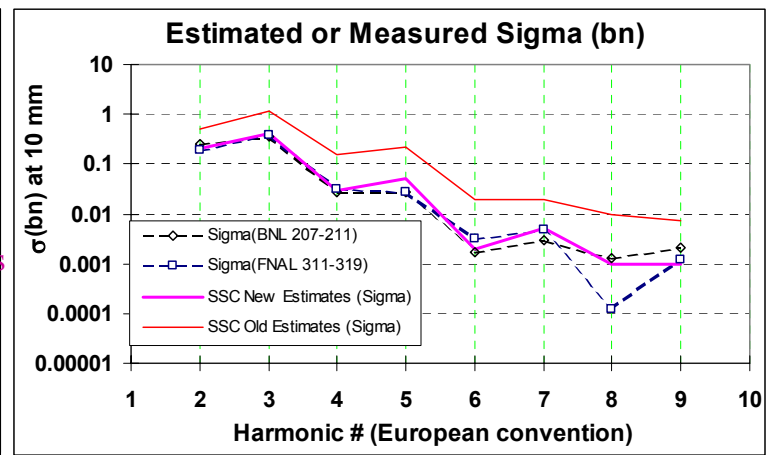
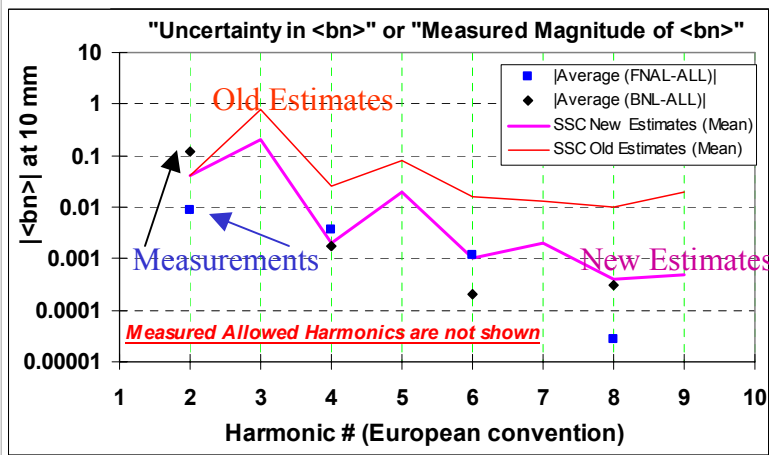

Field Errors in SSC dipoles

How off we were from reality?

Expected and Measured Harmonics at 2 T in SSC Dipoles (previously shown in LOG scale at 10 mm)

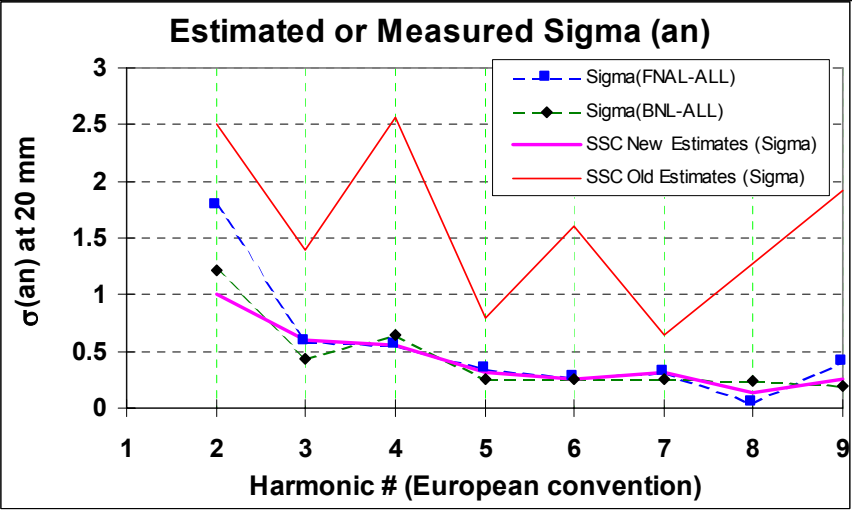
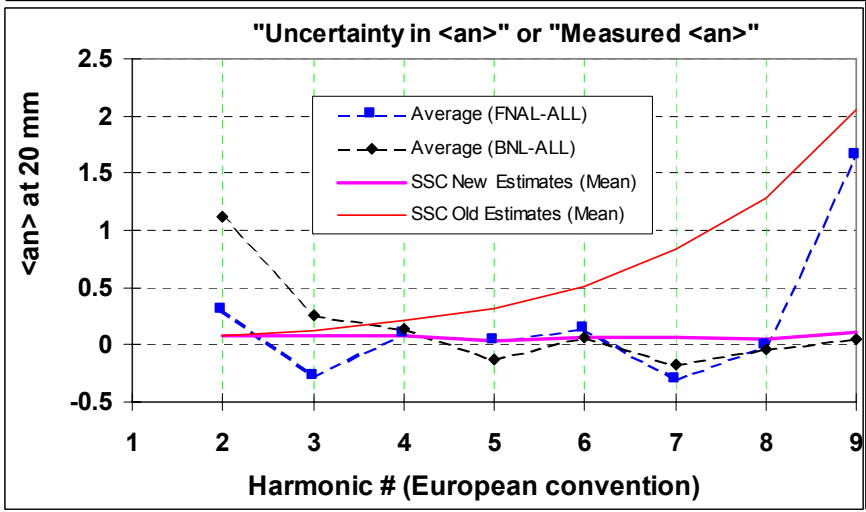
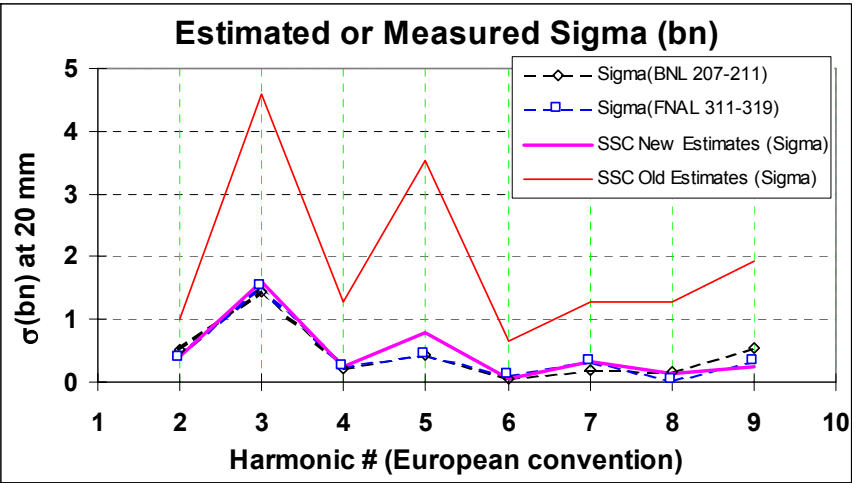
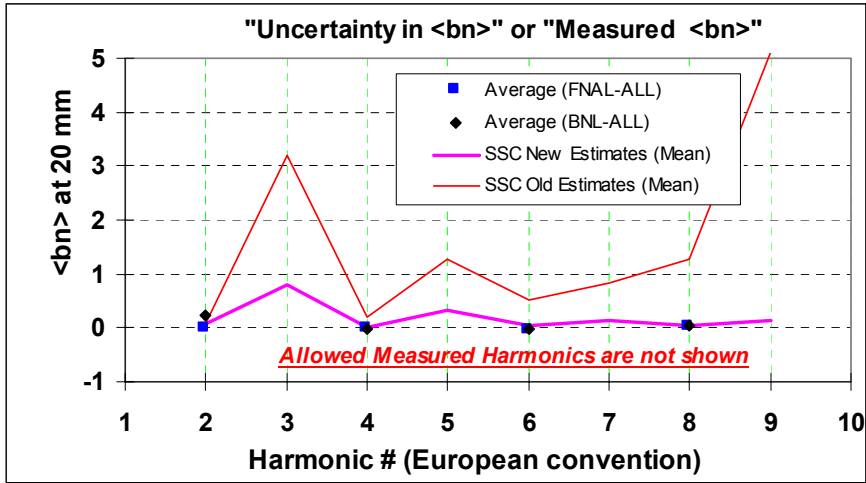

Why were we so wrong in estimating field errors in SSC dipoles?

Popular Models

Ignore the source of error and displace various conductor blocks at random by 25-50 micron
Assumption: it simulates the error in parts and construction on field harmonics.

Add the resultant field errors in an RMS way.

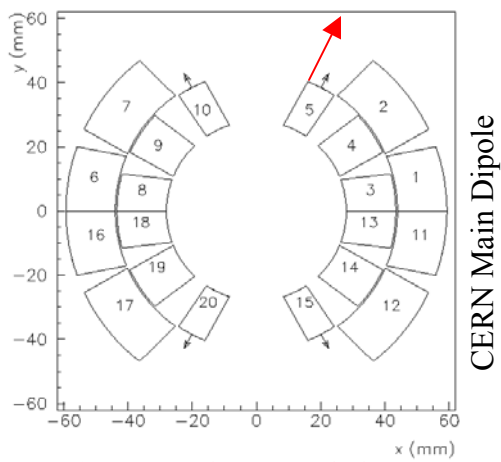

Movement in popular models: one red arrow

Symmetric model: 4 black arrows

Realistic model: some thing in between but closer to black arrows

A More Realistic Model

The errors in parts do not necessarily translate to the error in field harmonics. The effect of geometric errors gets significantly reduced in magnets due to averaging and symmetry considerations.

For example consider how a systematic or random error in collar, wedge or cable works in a magnet.

How about the critical coil curing?

Error in collar here

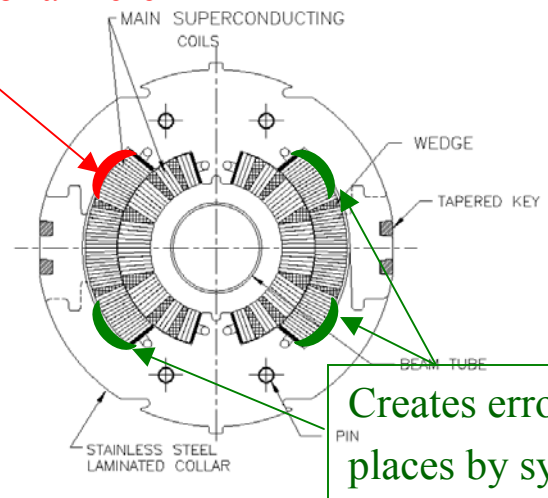

Creates error at other places by symmetry

Measured Current Dependence in Sextupole in SSC Magnets

Measurement of b2 current dependence in group of SSC magnets
Various SSC 40 and 50 mm dipoles

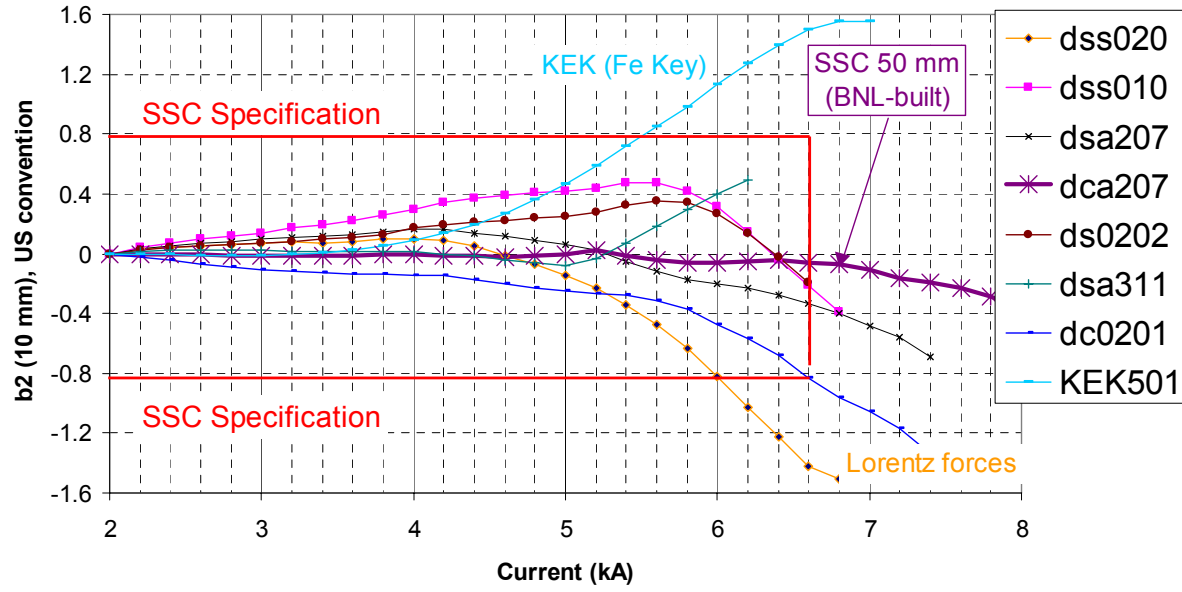

Cross section of SSC 50 mm Dipole
Yoke optimized for low saturation

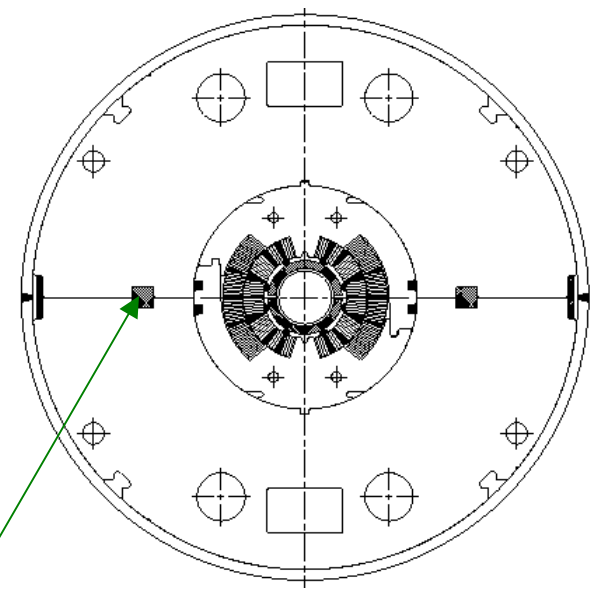

Non-magnetic key to force uniform saturation
Can also be used to adjust current dependence during production (done in RHIC magnets).

Major progress in reducing the saturation induced harmonics.

Near zero current dependence in sextupole in first 50 mm design itself in BNL built long magnets.

Specifications was 0.8 unit.

Earlier magnets (40 mm) had a much larger value.
(Source: Iron saturation and Lorentz forces)

Influence of Lorentz Forces

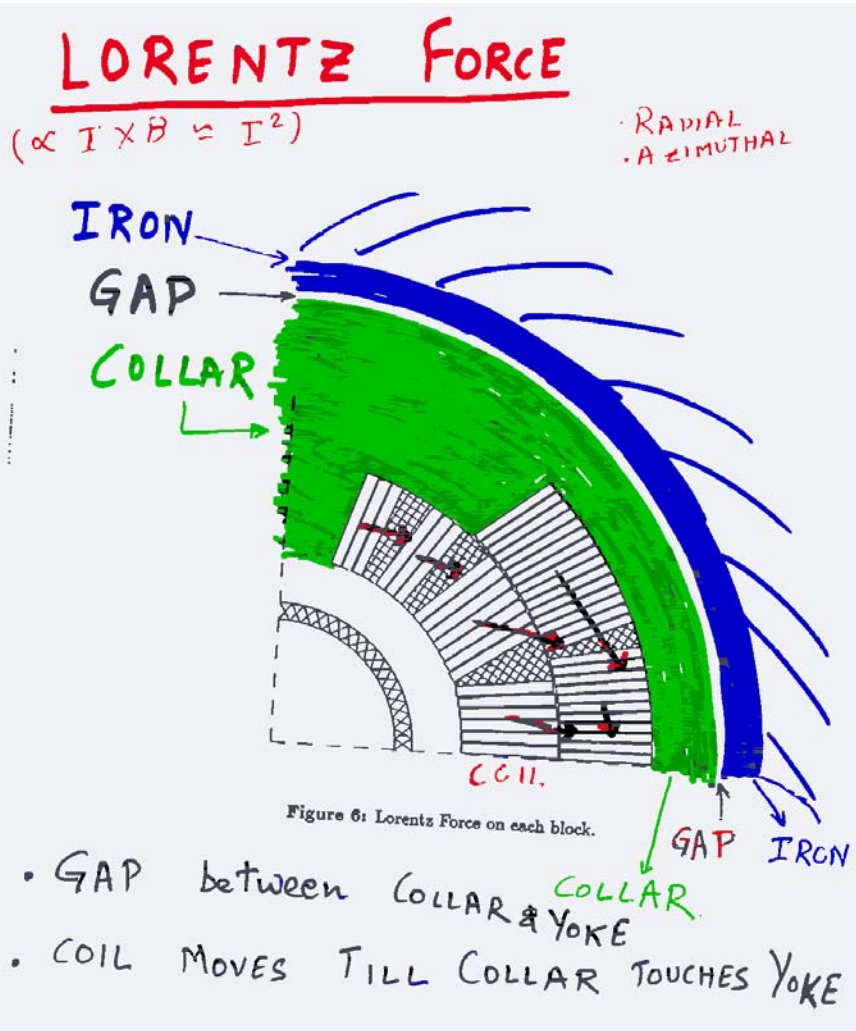

A typical Sextupole current dependence due to Lorentz forces (schematic)

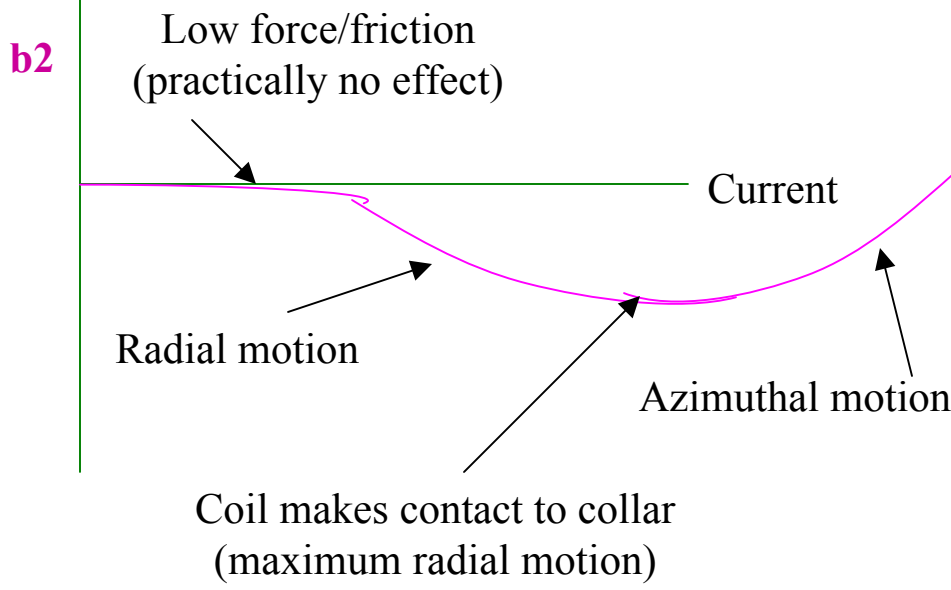

A small radial gap in some SSC prototype magnets (75-100 micron, almost allowed by errors due to spec) gave about 1 unit of negative sextupole. Such things can be accommodated in a flexible design.

Note: The measured current dependence is a combination of saturation induced harmonics and Lorentz force induced harmonics.

Feedback in design from HERA experience: The Real Magnet Vs. Paper Design

Superconducting
Magnet Division

Note: Integral B.dl

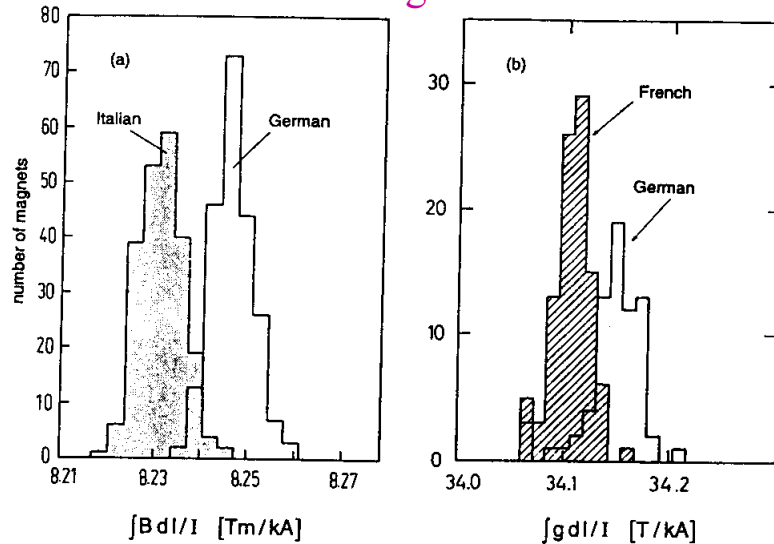
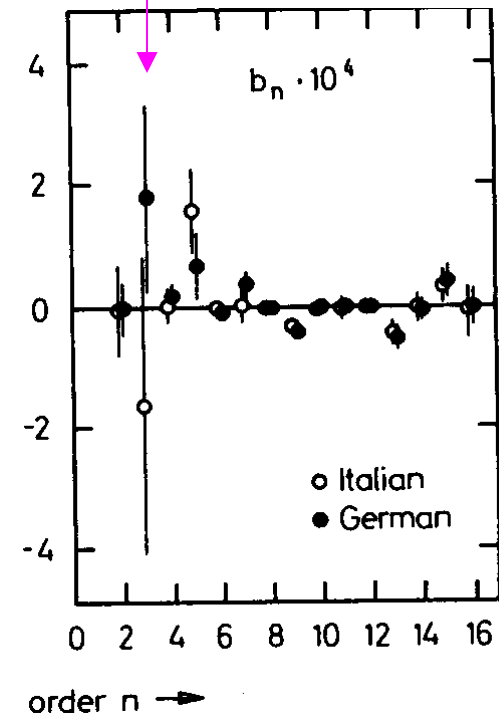

Figure 5.5: (a) Field integral of all HERA dipoles, normalized to coil current. (b) Integrated gradient of all quadrupoles, normalized to coil current (Brück et al. 1991).

Note: Sextupole



- Parameters do deviate from nominal value.
- It takes time to locate the cause of the problem and then fix it (conventionally that included a cross section iteration). Takes too long and the magnet production can not stop.
- A good design strategy would anticipate such deviations.
- Make a flexible design that assures good field quality despite such deviations.

Feedback in design from HERA experience

A Method to Adjust Integral Field and Skew Quad

Superconducting
Magnet Division

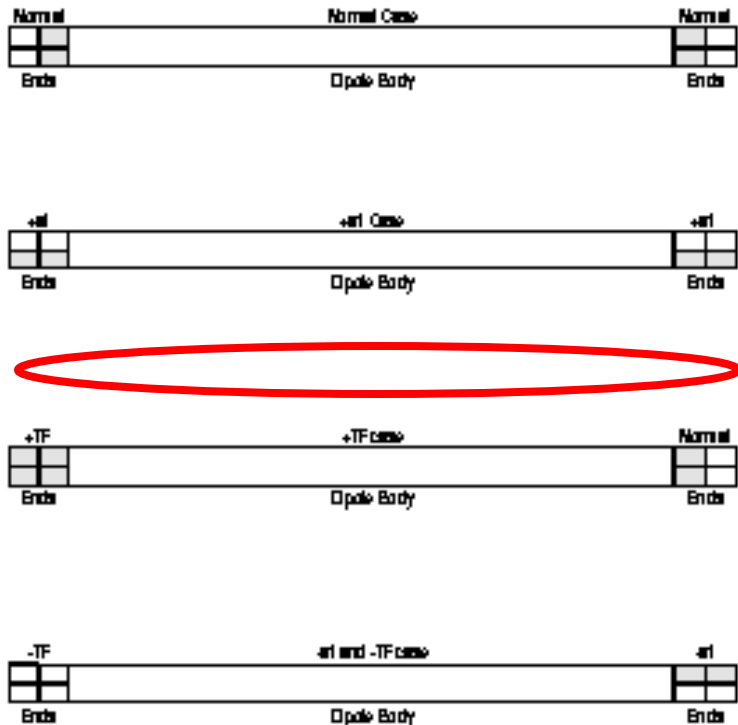

Figure 4.3.1: A conceptual diagram for correcting the integral a_1 harmonic and integral transfer function in a superconducting dipole magnet. The proposed adjustment is applied in the end region of the magnet. The actual starting point would be somewhere in the dipole body where the field is still high. In the normal case (top figure) the change between the magnetic, low carbon steel laminations (dark or filled) and non-magnetic stainless steel laminations (light or empty) occurs at a nominal location. Interchanging the stainless steel and low carbon steel laminations between top and bottom halves (second figure) creates an a_1 which can be used to compensate the measured a_1 in a magnet. Increasing the number of low carbon steel magnetic laminations increases the integral transfer function (third figure). An adjustment (decrease) in both a_1 and integral transfer function can be obtained together by mixing the two schemes in the same magnet (bottom figure).

Iron laminations were successfully used in RHIC to adjust transfer function saturation in different length magnets and to control skew quad in main dipoles.

Three magnets with similar apertures Tevatron, HERA and RHIC

Tevatron Dipole (76.2 mm bore)

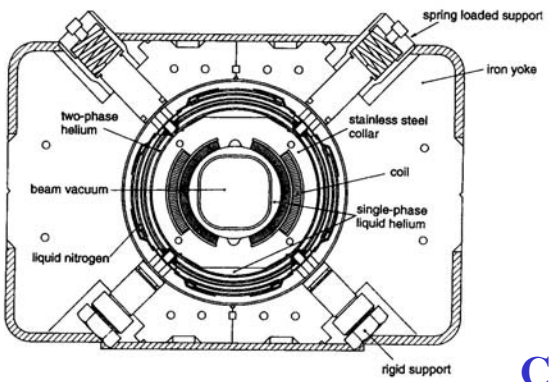
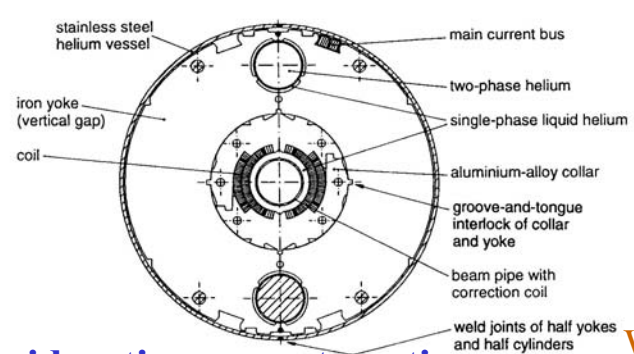

Figure 4.9: The Tevatron 'warm-iron' dipole (Tollestrup 1979).

No Wedges (large higher order systematic harmonics expected).
S.S. Collars - Iron away from coil (small saturation expected).

HERA Dipole (75 mm bore)



Consideration on systematic errors

Wedges (small higher order harmonics expected).
Al Collars - Iron away from coil (small saturation expected).

RHIC Dipole (80 mm bore)

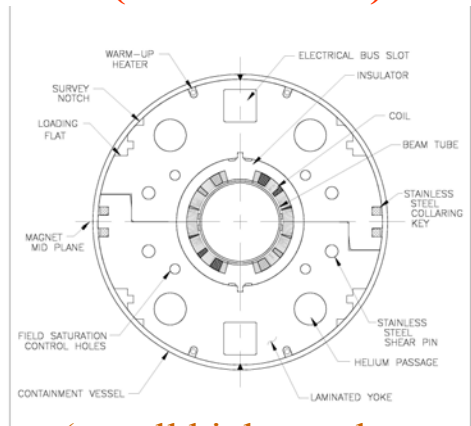

Wedges (small higher order harmonics expected).
Thin RX630 spacers to reduce cost - Iron close to coil (large saturation from conventional thinking. **But reality opposite: made small with design improvements).**

Collars used in Tevatron and HERA dipoles have smaller part-to-part dimensional variation (RMS variation $\sim 10 \mu$) as compared to RX630 spacers (RMS variation $\sim 50 \mu$) used in RHIC dipoles.
Conventional thinking : RHIC dipoles will have larger RMS errors. But in reality, it was opposite.
Why? The answer changes the way we look at the impact of mechanical errors on field quality !

Comparison of Field Quality in three similar aperture magnets

	Tevatron	HERA	RHIC
Reference Radius (mm)	25.4	25	25
Coil Diameter (mm)	76.2	75	80

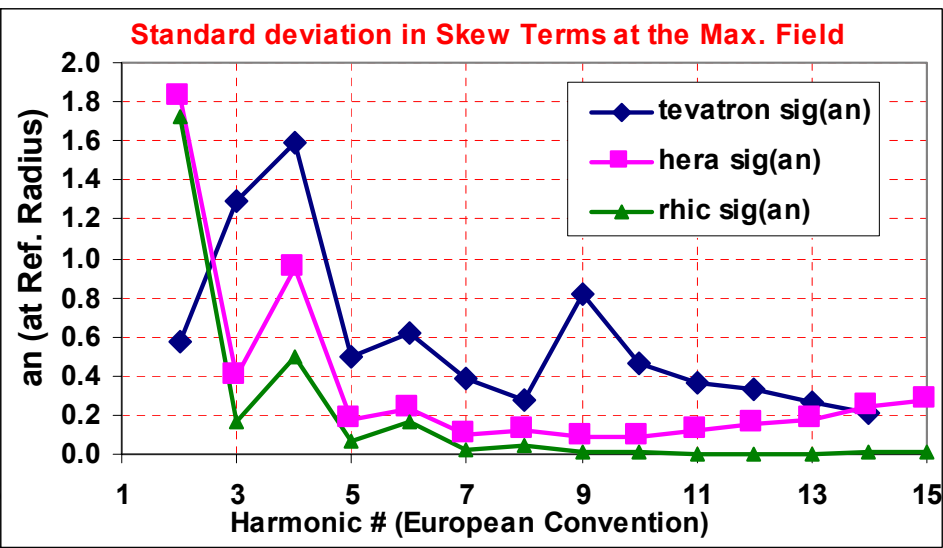
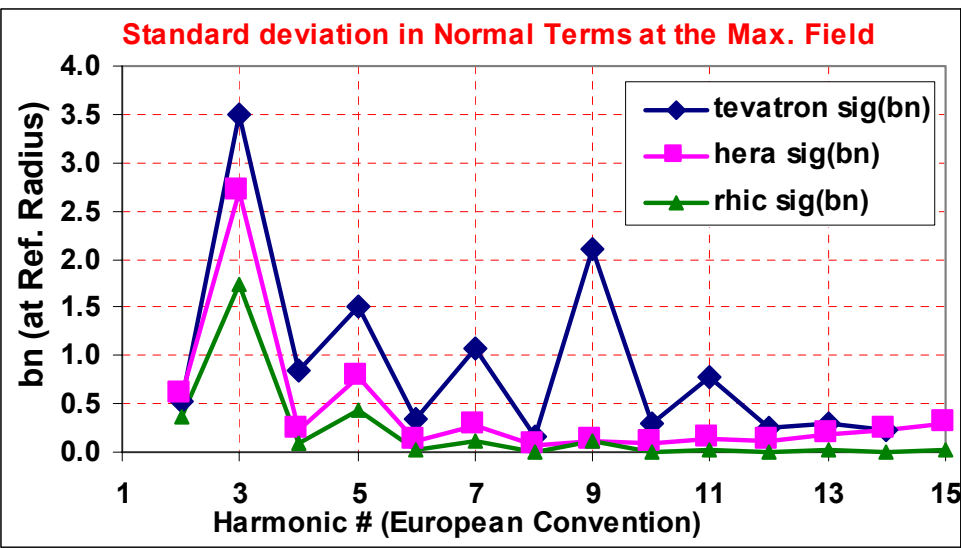

RHIC has lower sigmas (except for a2 where tevatron used smart bolts)

Lower Order Harmonics generally due to Construction Errors
Higher Order Harmonics generally due to Measurement Errors

Comparison of Field Quality in Tevatron, HERA and RHIC dipoles

(Large scale production of similar aperture magnets)

Here the normal and skew harmonics are presented in LOG scale. They were shown earlier in linear scale.

	Tevatron	HERA	RHIC
Reference Radius (mm)	25.4	25	25
Coil Diameter (mm)	76.2	75	80

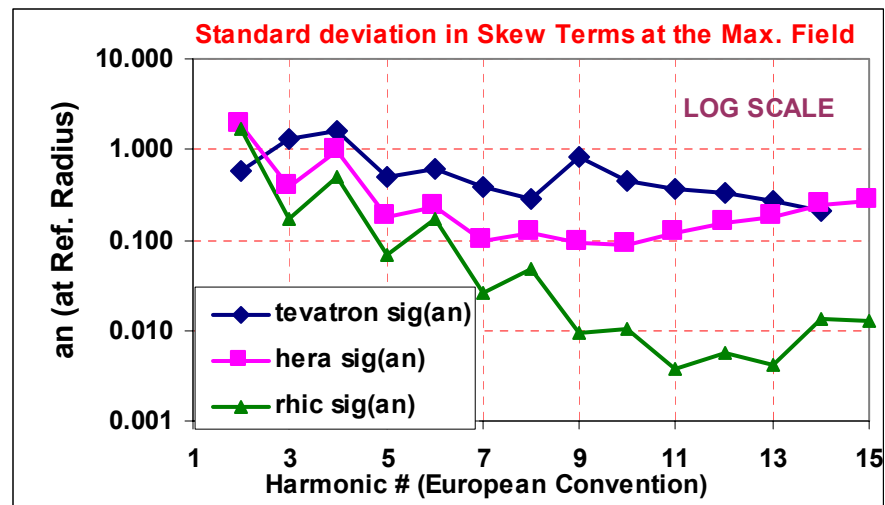
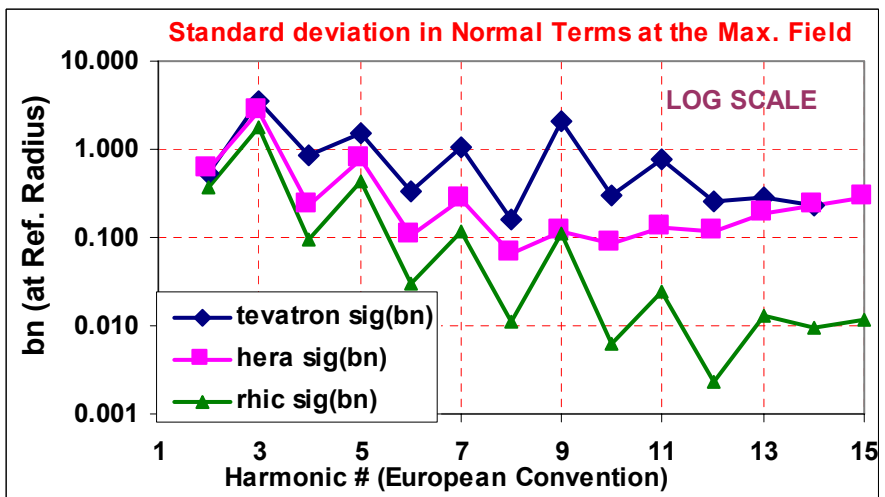

RHIC has lower sigmas (except for a2 where tevatron used smart bolts)

Lower Order Harmonics generally due to Construction Errors

Higher Order Harmonics generally due to Measurement Errors

Relaxation of Tolerances

- Laminated collars have small random errors (5-10 micro) because of the way they are made.
- In RHIC injection molded RX630 spacer had much larger random errors (~50 micron).
- Because of this one would have expected larger field errors (RMS) in RHIC magnets. Yet the errors in RHIC were smaller than that in similar production (Tevatron and HERA).
- Implication: The tolerances in parts that are used in large numbers may be relaxed because the influence of error gets reduced due to averaging and symmetry effects.

Errors in Modern Measurement System

A. Jain and P. Wanderer, BNL

Summary of various contributions to measurement errors. The normal and skew harmonics are indicated using the US notation (b_1 = normal quadrupole, etc.)

Harmonic	Maximum error due to meas. coil construction/calibration (units)	Effect of thermal cycle and/or quench (units)	Effect of time dependence, at 5kA (units)	Random error in measurement (units)	Total expected error (units)	Suggested value of total measurement uncertainty (units)
b_1	0.011	0.006	0.0	0.061	0.078	0.10
b_2	0.085	0.203	0.1	0.033	0.420	0.50
b_3	0.004	0.009	0.0	0.012	0.026	0.05
b_4	0.022	0.044	0.0	0.004	0.071	0.10
b_5	0.002	0.012	0.0	0.003	0.016	0.02
b_6	0.012	0.005	0.0	0.002	0.019	0.02
b_7	0.001	0.000	0.0	0.001	0.003	0.02
b_8	0.009	0.003	0.0	0.001	0.013	0.02
b_9	0.001	0.004	0.0	0.001	0.006	0.02
b_{10}	0.020	0.001	0.0	0.001	0.022	0.05
b_{11}	0.000	0.002	0.0	0.001	0.003	0.02
b_{12}	0.009	0.002	0.0	0.001	0.012	0.02
b_{13}	0.003	0.002	0.0	0.002	0.006	0.02
b_{14}	0.041	0.004	0.0	0.002	0.047	0.05
a_1	0.046	0.388	0.0	0.043	0.477	0.50
a_2	0.019	0.000	0.0	0.015	0.034	0.05
a_3	0.019	0.027	0.0	0.010	0.056	0.10
a_4	0.006	0.002	0.0	0.005	0.013	0.02
a_5	0.010	0.009	0.0	0.004	0.023	0.05
a_6	0.004	0.000	0.0	0.002	0.006	0.02
a_7	0.004	0.001	0.0	0.002	0.006	0.02
a_8	0.001	0.006	0.0	0.001	0.008	0.02
a_9	0.001	0.001	0.0	0.001	0.003	0.02
a_{10}	0.001	0.001	0.0	0.001	0.003	0.02
a_{11}	0.001	0.001	0.0	0.001	0.003	0.02
a_{12}	0.001	0.008	0.0	0.001	0.010	0.02
a_{13}	0.002	0.001	0.0	0.002	0.005	0.02
a_{14}	0.004	0.008	0.0	0.002	0.014	0.02

Very Small Measurement Errors in RHIC

Shows that errors in the measurement system can be so small that it need not limit the expected or measured field harmonics in modern magnets.

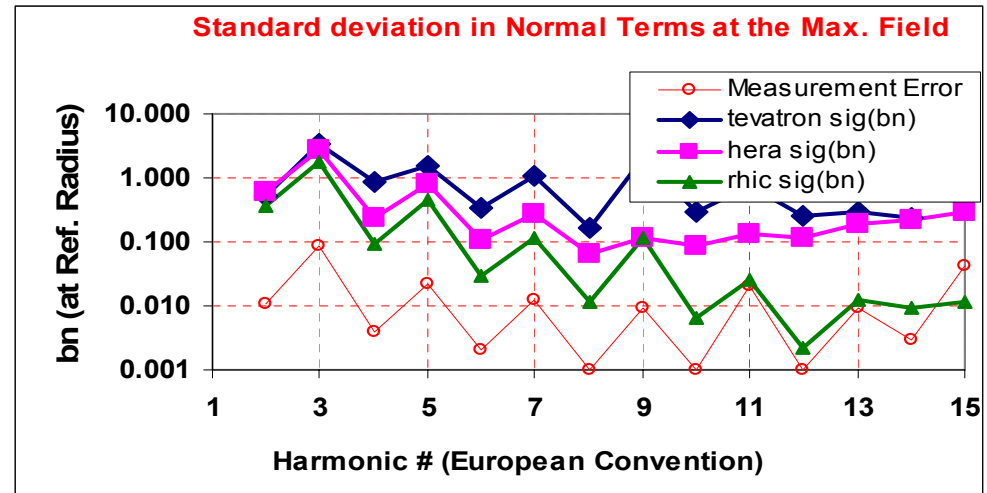

Different Size Cable (within spec) from Two Different Vendors

Specifications : +/- 0.25 mil (6.5 micron); 0.5 mil variation (13 micron)

Two vendors gave cable
which differ systematically
(but within specifications)
by ~ 0.35 mil
(however, had a small RMS)

27 turns => 9 mil (0.24 mm)
much larger than desired.

A flexible design
accommodated it!

Cable Mid-Thickness Vs CableID (36--sd OST Cable used for Q1 Coils)

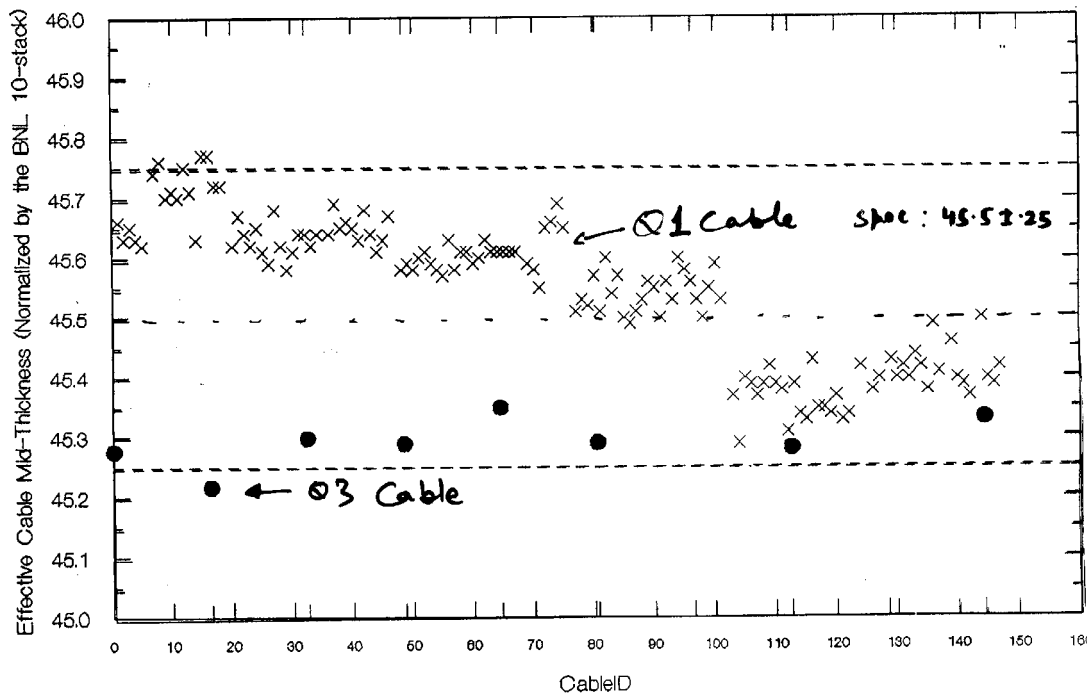

x Q1 Cable
• Q3 Cable

RHIC 130 mm Insertion Quad

Flexible Design
(Adjustment in b_5 During Production in Q1)

1. Design Changes (large) During Production
2. The Magic of Tuning Shims

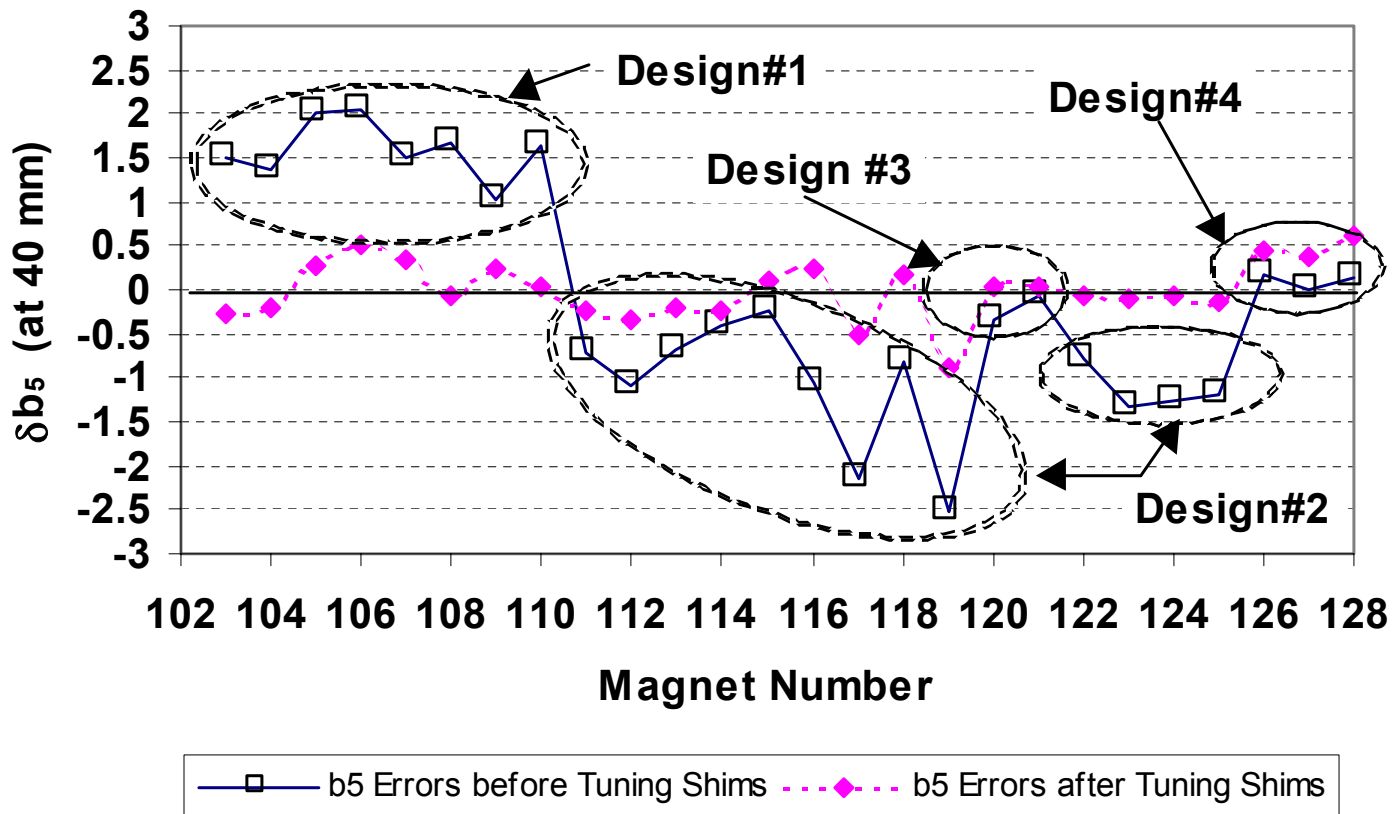

Saturation in RHIC Arc Dipoles

Superconducting
Magnet Division

In RHIC iron is closer to coil and contributes ~ 50% of coil field

**3.45 T (Total) ~ 2.3 T (Coil)
+ 1.15 (Iron)**

Initial design had bad saturation
(as expected from conventional wisdom),
but a number of developments made the
saturation induced harmonics nearly zero!

Only full length magnets are shown.
Design current is ~ 5 kA (~3.5 T)

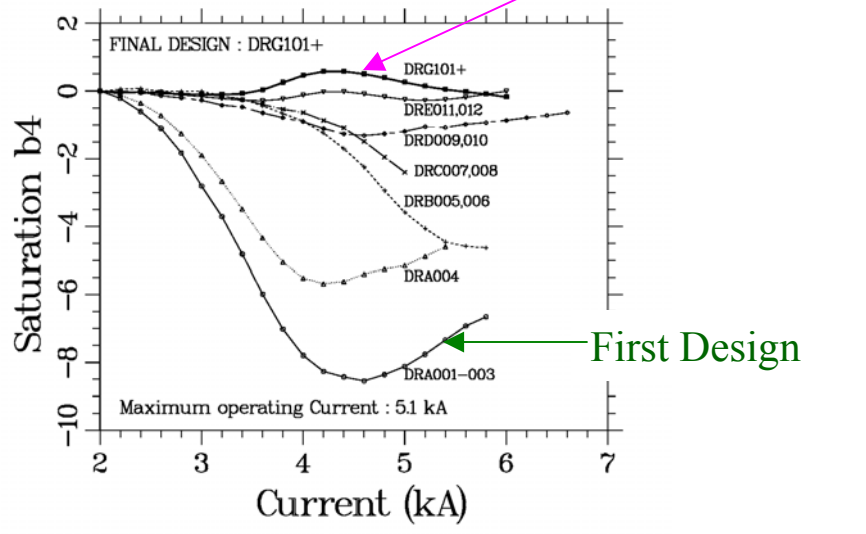
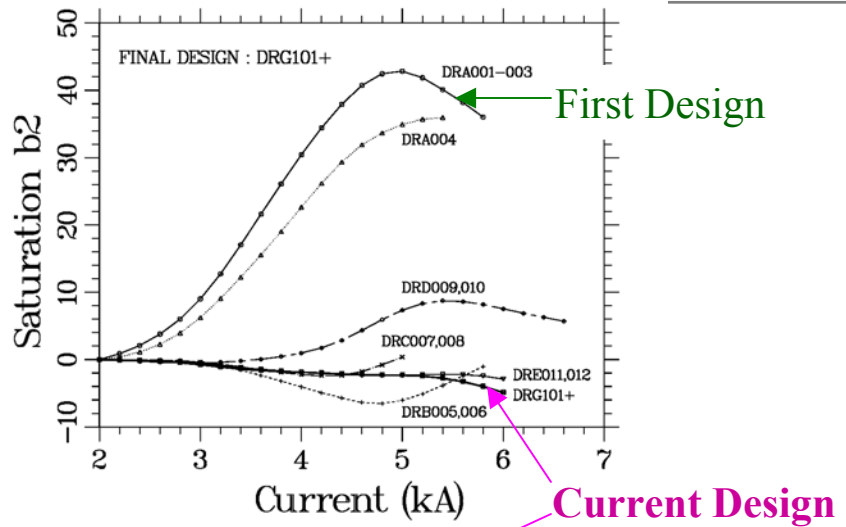

Saturation Control in RHIC Dipoles

Variation in $|B|$ in Iron Yoke

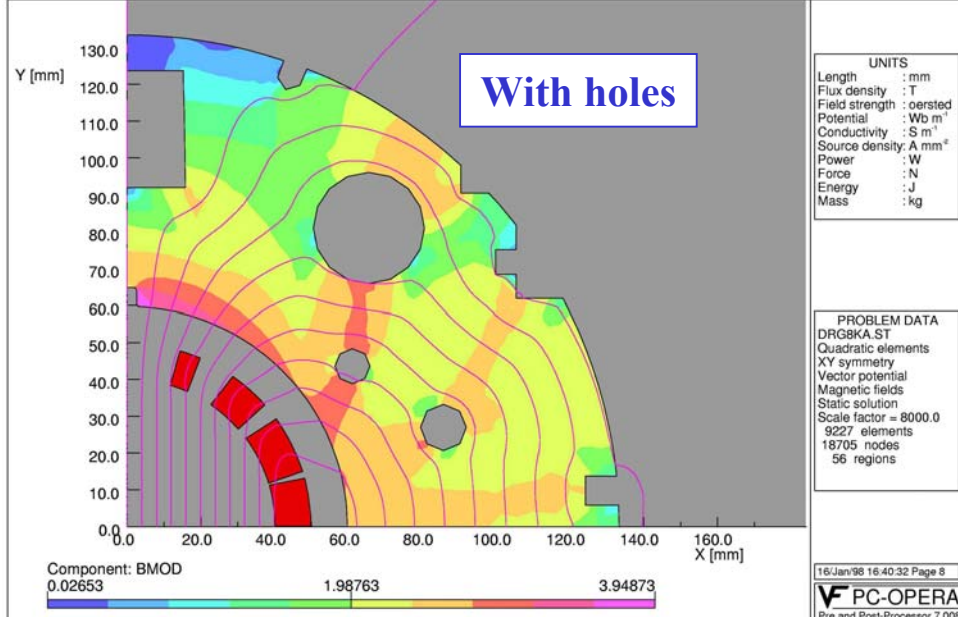
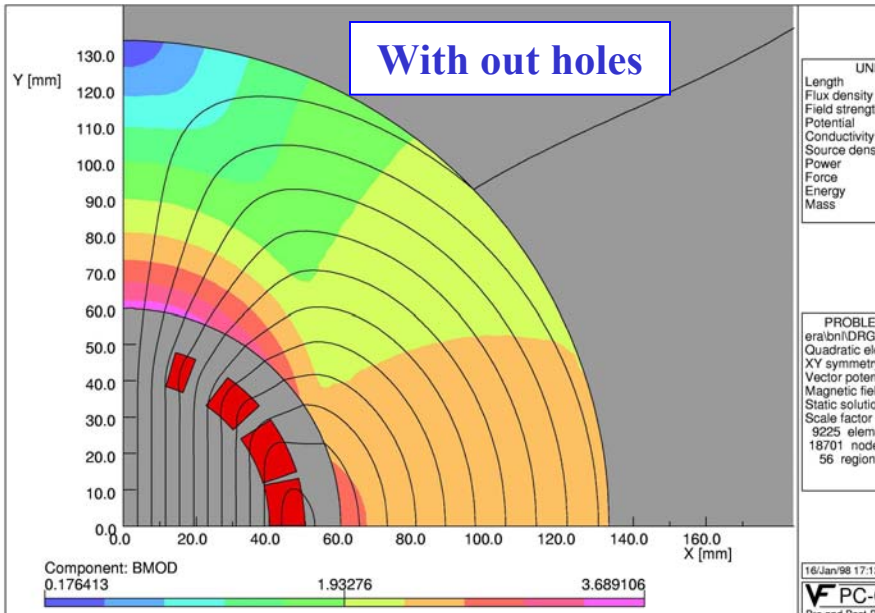

- Compare azimuthal variation in $|B|$ with and without saturation control holes. Holes, etc. increase saturation in relatively lower field regions; a more uniform iron magnetization reduces the saturation induced harmonics.
- Old approach: reduce saturating iron with elliptical aperture, etc.
- New approach: increase saturating iron with holes, etc. at appropriate places.

Average Field Errors on X-axis

COIL ID : RHIC 80 mm, HERA 75 mm, Tevatron 76.2 mm

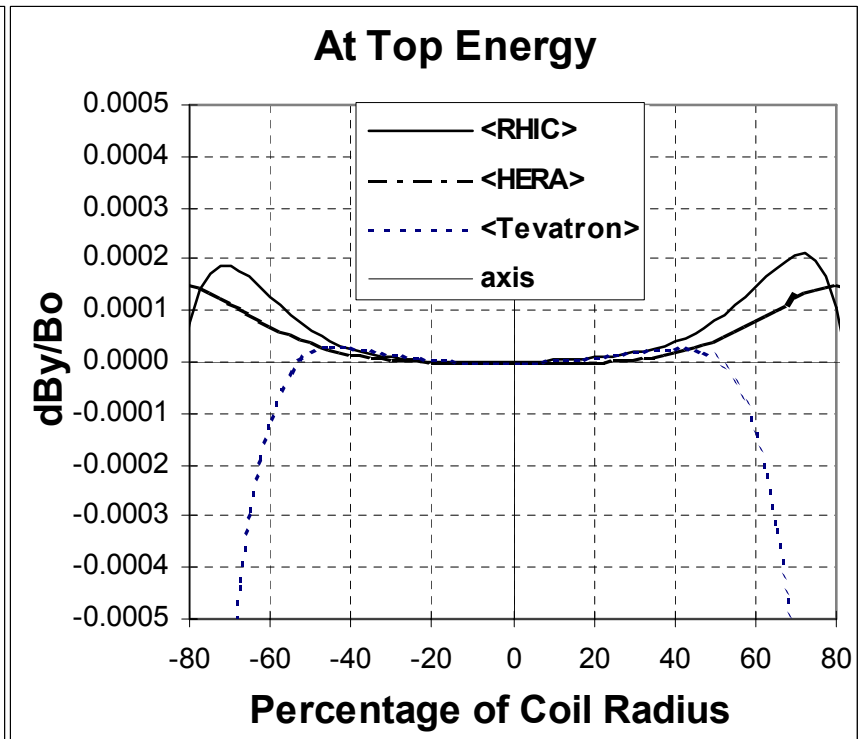
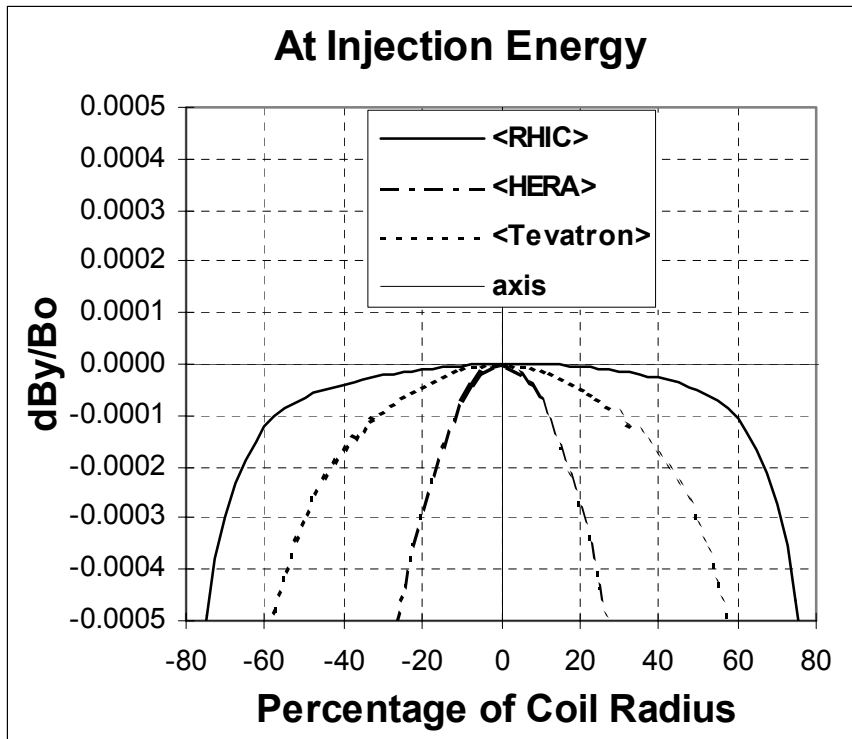

- Warm-Cold correlation have been used in estimating cold harmonics in RHIC dipoles (~20% measured cold and rest warm).
- Harmonics b_1 - b_{10} have been used in computing above curves.
- In Tevatron higher order harmonics dominate, in HERA persistent currents at injection. RHIC dipoles have small errors over entire range.

Lessons Learnt from the RHIC Dipole Production

- Reduction in random errors despite RX630 spacers with a larger dimensional variations. Symmetry and averaging reduce the effect of errors.
- Improvements in coil manufacturing and measurements system also played a major role.
- Small current dependence in harmonics despite the close-in iron.
- Small systematic and shown that it can be controlled during large production.

- Such a good field quality means that the corrector magnets are NOT likely to be needed in RHIC for correcting field errors in arc dipoles.

The sextupole magnets will be used for persistent current induced b_2 and for other beam dynamics purpose (chromaticity correction); may also be used for removing a relatively small residual b_2).

RHIC 100 mm Aperture Insertion Dipole: The first magnet gets the body harmonics right

Geometric Field Errors on the X-axis of DRZ101 Body

First magnet and first attempt in RHIC 100 mm aperture insertion dipole

A number of things were done in the test assembly to get pre-stress & harmonics right

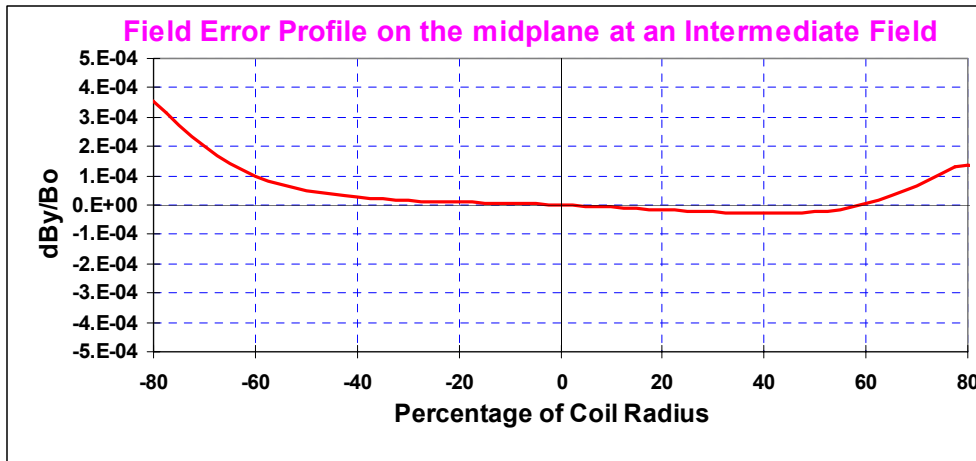

Note: Field errors are within 10^{-4} at 60% of coil radius and $\sim 4 \cdot 10^{-4}$ at 80% radius.

Later magnets had adjustments for integral field and saturation control.
The coil cross-section never changed.

Harmonics at 2 kA (mostly geometric).
Measured in 0.23 m long straight section.

Reference radius = 31 mm

b1	-0.39	a2	-1.06
b2	-0.39	a3	-0.19
b3	-0.07	a4	0.21
b4	0.78	a5	0.05
b5	-0.05	a6	-0.20
b6	0.13	a7	0.02
b7	-0.03	a8	-0.16
b8	0.14	a9	-0.01
b9	0.02	a10	0.01
b10	-0.04	a11	-0.06
b11	0.03	a12	-0.01
b12	0.16	a13	0.06
b13	-0.03	a14	0.03
b14	-0.10	a15	0.02

All harmonics are within or close to one sigma of RHIC arc dipoles.

**Average Field errors $\sim 10^{-4}$
up to 80% of the coil radius**

Geometric Field Errors on the X-axis of RHIC DRZ magnets (108-125)
Coil Cross section was not changed between prototype and production magnets
A Flexible & Experimental Design Approach Allowed Right Pre-stress & Right Harmonics

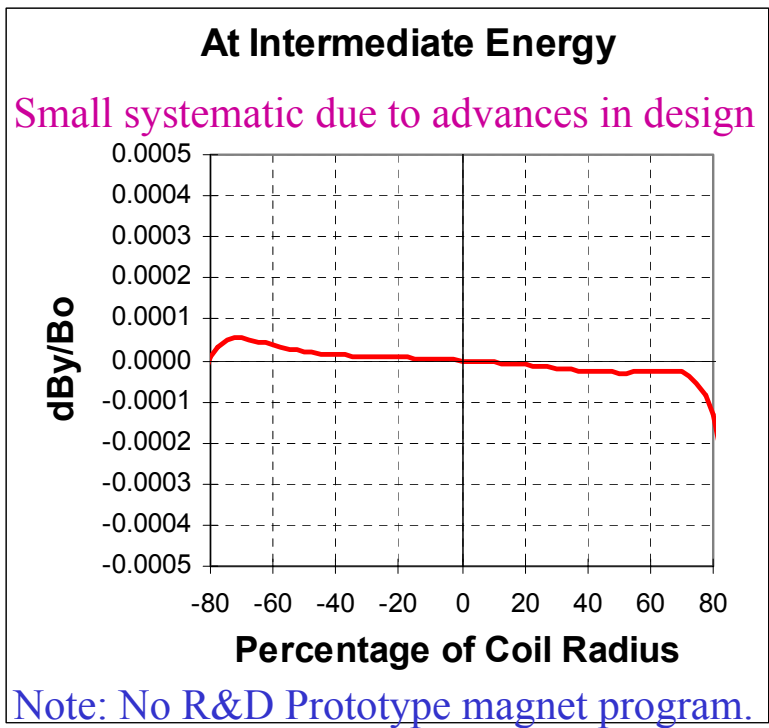

Estimated Integral Mean in Final Set
(Warm-cold correlation used in estimating)
Harmonics at 3kA (mostly geometric)
Reference radius is 31 mm (Coil 50 mm)

b1	-0.28	a1	-0.03
b2	-0.26	a2	-3.36
b3	-0.07	a3	0.03
b4	0.15	a4	0.48
b5	0.00	a5	0.04
b6	0.32	a6	-0.24
b7	0.00	a7	0.01
b8	-0.08	a8	0.05
b9	0.00	a9	0.00
b10	-0.12	a10	-0.02
b11	0.03	a11	-0.01
b12	0.16	a12	0.06
b13	-0.03	a13	0.03
b14	-0.10	a14	0.02

**Raw Data Provided by Animesh Jain at BNL*

Field errors are 10^{-4} to 80% of the aperture at midplane.
(Extrapolation used in going from 34 mm to 40 mm; reliability decreases)

Tuning Shims for 10^{-5} Field Quality at $2/3$ of coil radius

GOAL : Make field errors in magnets much smaller than that is possible from the normal tolerances.

Basic Principle of Tuning Shims:

Magnetized iron shims modify the magnet harmonics.

Eight measured harmonics are corrected by adjusting the amount of iron in eight Tuning Shims.

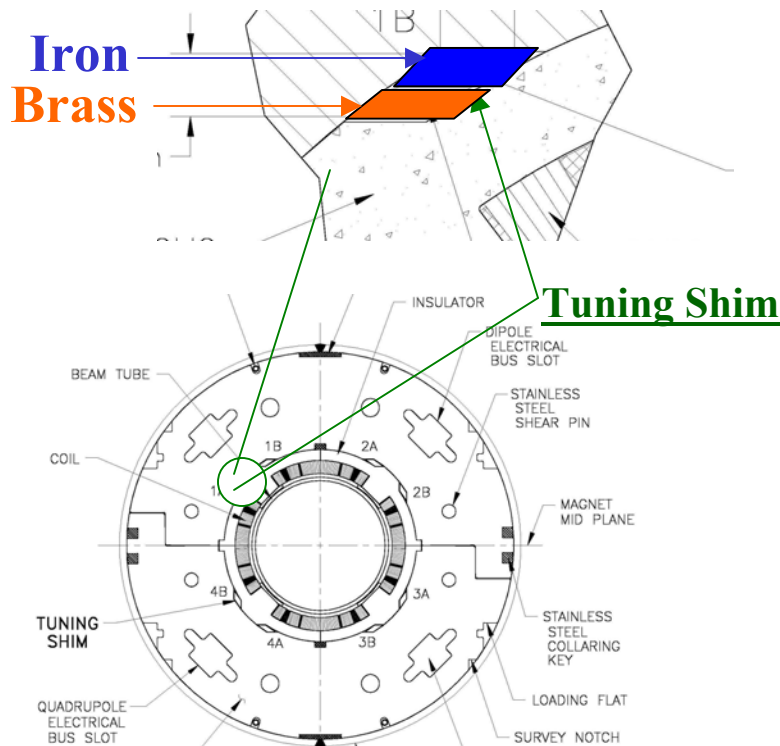

Procedure for using tuning shims in a magnet:

1. Measure field harmonics in a magnet.
2. Determine the composition of magnetic iron (and remaining non-magnetic brass) for each of the eight tuning shim. In general it would be different for each shim and for each magnet.
3. Install tuning shims. The tuning shims are inserted without opening the magnet (if the magnet is opened and re-assembled again, the field harmonics may get changed by a small but a significant amount).
4. Measure harmonics after tuning shims for confirmation.

Field Quality Improvements with Tuning Shims (Skew Harmonics)

Mean

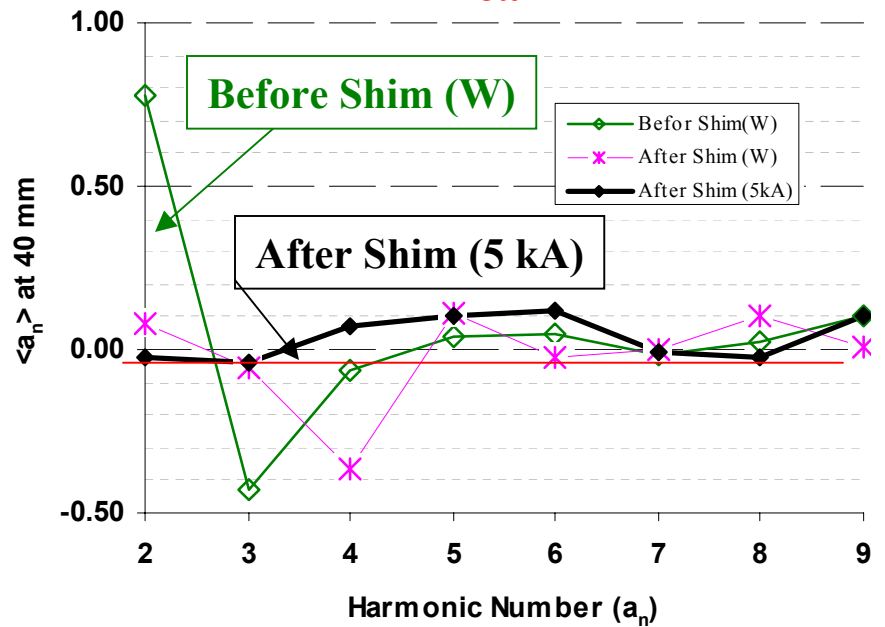

Standard Deviations

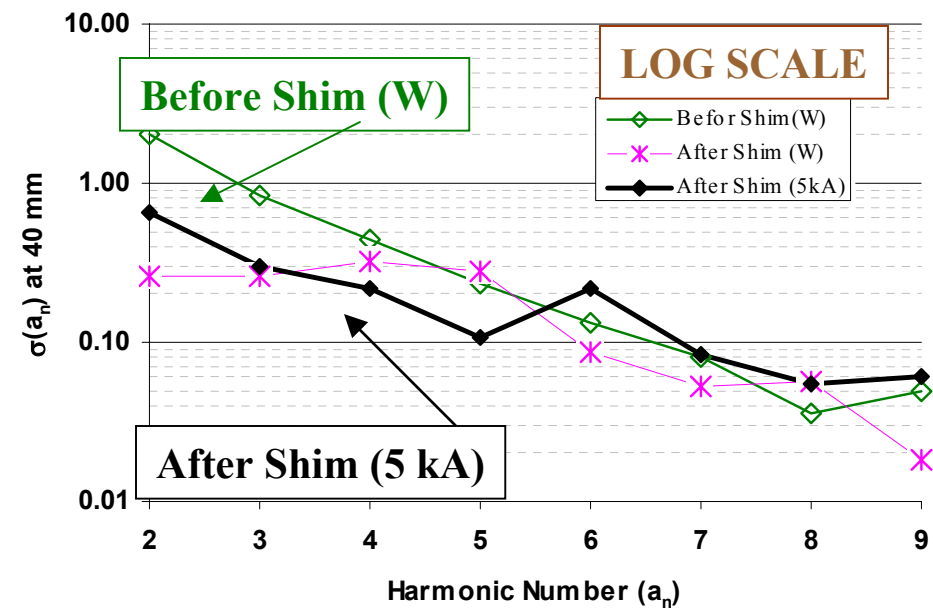

n	$\langle a_n \rangle$ (n=2 is sextupole)			$\sigma(a_n)$		
	Before Shim(W)	After Shim (W)	After Shim (5kA)	Before Shim(W)	After Shim (W)	After Shim (5kA)
2	0.77	0.08	-0.02	2.04	0.26	0.65
3	-0.43	-0.05	-0.04	0.84	0.26	0.30
4	-0.07	-0.36	0.07	0.45	0.33	0.22
5	0.04	0.11	0.10	0.24	0.28	0.11
6	0.05	-0.03	0.12	0.14	0.09	0.22
7	-0.02	0.00	-0.01	0.08	0.05	0.08
8	0.02	0.11	-0.03	0.04	0.06	0.05
9	0.10	0.01	0.11	0.05	0.02	0.06

Ultimate Field Quality in SC Magnets

**Superconducting
Magnet Division**

A magnet properly designed with “Tuning Shims” should theoretically give a few parts in 10^5 harmonics at $2/3$ of coil radius (i.e. practically zero).

Animesh Jain at BNL found changes in harmonics between two runs in RHIC insertion quadrupoles.

First thought that the changes were related to the tuning shims.

Later, an experimental program found that the harmonics change after quench and thermal cycles in other magnets also. These changes perhaps put an ultimate limit on field quality.

Changes may be smaller in magnets made with S.S. collars.

Note: n=2 is sextupole

Harmonic Changes during Quench and Thermal Cycles

Magnets : QRK101/102; All Runs (DC loops at 3 kA)
(In tuning shim runs, the harmonics are made zero to the first warm run)

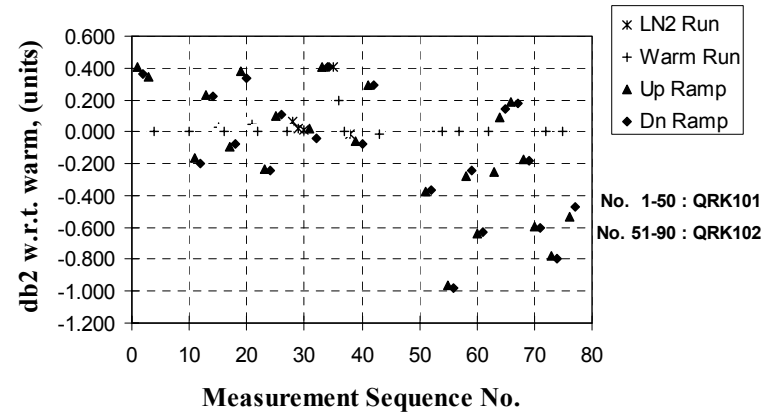

Harmonic Changes during Quench and Thermal Cycles

Magnets : QRK101/102; All Runs (DC loops at 3 kA)

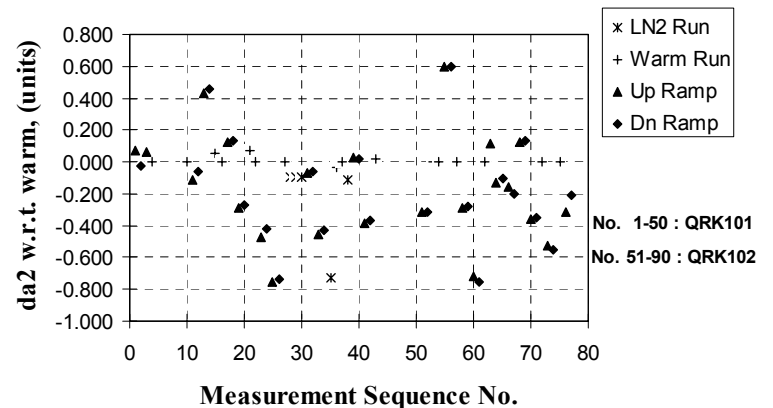

Field Quality in Common Coil Design

- Geometric harmonics
 - an inherent up-down asymmetry both in the body and in the ends
 - A proof of principle solution that overcomes this asymmetry.
- => A field quality comparable to cosine theta designs by using a similar amount of conductor.**
- Should remove the age-old conventional wisdom that “block designs” use more conductor than the “cosine theta magnets”.
- * We just have to optimize the design a bit more carefully! *
- Saturation induced harmonics
 - Persistent current induced harmonics
 - could be a serious problem in Nb_3Sn magnets.
 - The proposed solution brings major savings as a bonus.

Common Coil Design

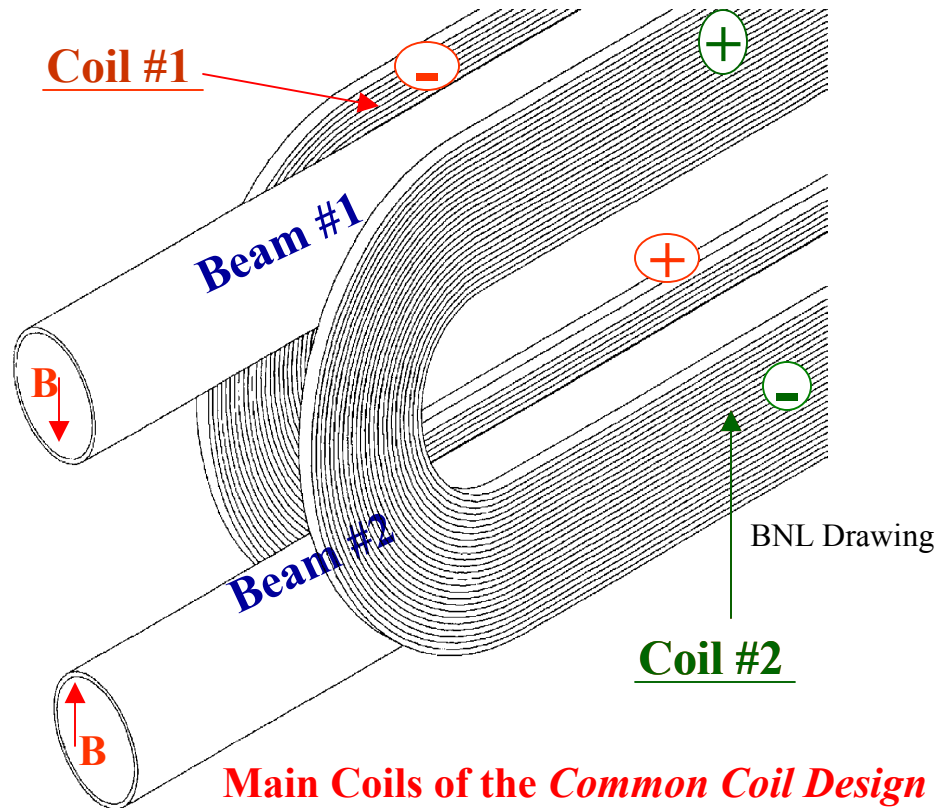
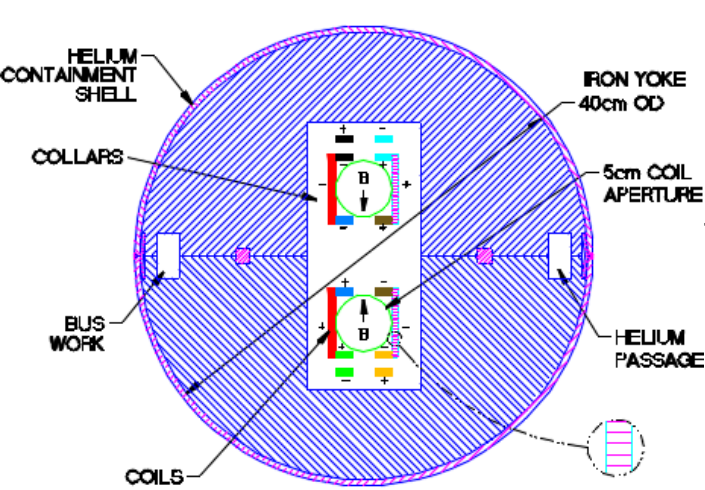

- **Simple 2-d** geometry with large bend radius (no complex 3-d ends)
- **Conductor friendly** suitable for brittle materials (Nb_3Sn , HTS, etc.) and React & Wind coils
- **Compact** (compared to single aperture D20 magnet, half the yoke mass for two apertures)
- **Block design** (for large Lorentz forces at high fields)
- **Efficient** and methodical **R&D** due to simple & **modular design**
- **Minimum** requirements on big expensive **tooling and labor**
- *Lower cost magnets expected*

Field Quality Optimization in Common Coil Design (Magnet Body- Geometric)

A Proof of Principle Design
(still comparable to or better than
similar cosine theta designs)
ROXIE for real optimizations

All geometric harmonics

< 0.2 parts in 10^4 at 10 mm.

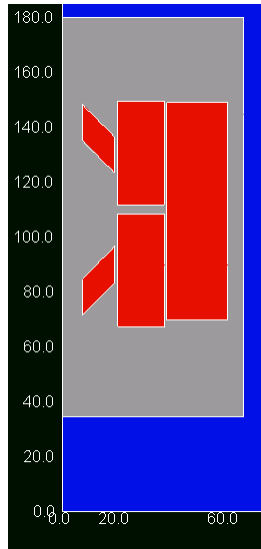

**Harmonics at 10 mm at 1.8 T in 10^{-4} units
(b2 is sextupole)**

Typical accelerator requirements: $\sim 10^{-4}$

N	SKEW(a_n)	NORMAL(b_n)
1	-0.01	0.00
2	0.00	0.00
3	0.01	0.00
4	0.00	0.04
5	0.02	0.00
6	0.00	0.05
7	0.01	0.00
8	0.00	-0.17
9	0.00	0.00
10	0.00	-0.03
11	0.00	0.00
12	0.00	0.00
13	0.00	0.00
14	0.00	0.00

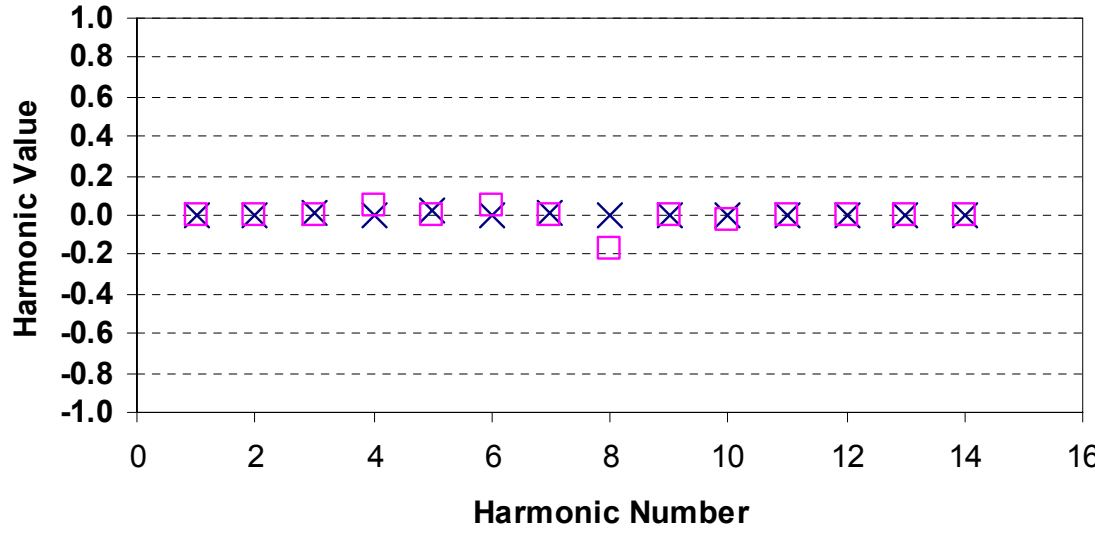

Field Quality Optimization in Common Coil Design (Magnet Body- Yoke Saturation)

A Proof of Principle Design
(still comparable to or better than
similar cosine theta designs)
ROXIE for real optimizations

A Compact Design (lower cost) 15 T 4-in-1 dipole.
2.4 times smaller than single aperture 13.5 T D20;
1.4 times smaller than dual aperture 9-10 T LHC

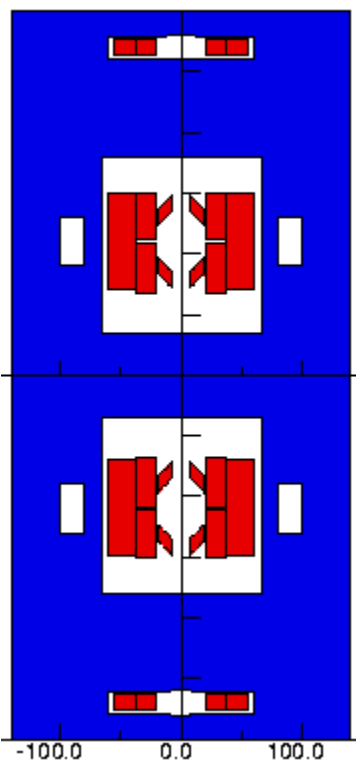

Iron saturation
(comparable to cosine theta designs)

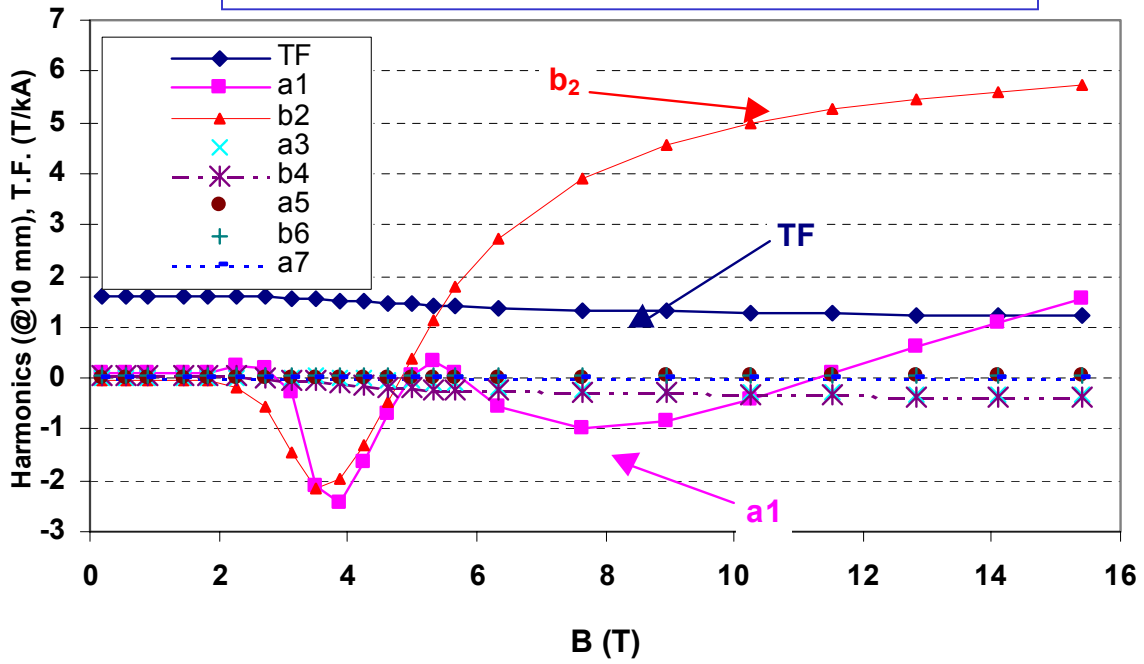

Field Quality Optimization in the Common Coil Design (Magnet Ends)

Up-down asymmetry gives large skew harmonics if done nothing. Integrate $B_y.dl$ 10 mm above and 10 mm below midplane.

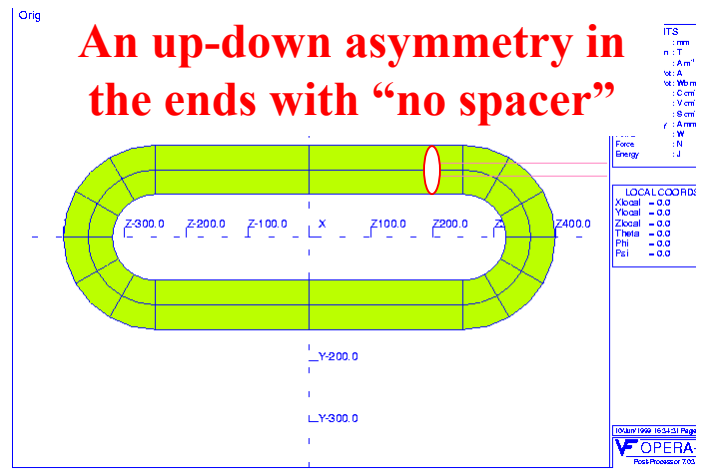

Up-down asymmetry can be compensated with end spacers. One spacer is used below to match integral $B_y.dl$ 10 mm above & below midplane.

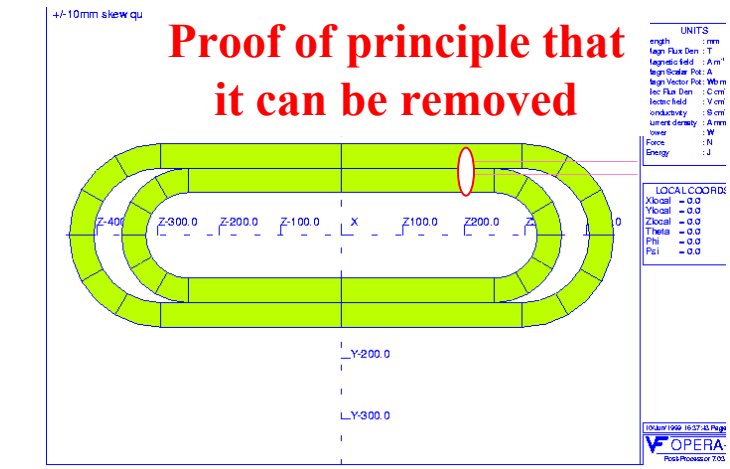

Computer code ROXIE (developed at CERN) will be used to efficiently optimize accelerator quality magnet design.
Young Post-doc (Suitbert Ramberger).

A large $B_z.dl$ in two ends (~1 T.m in 15 T magnet).

- Is it a problem?
- Examine AP issues.
- Zero integral.
- Lead end of one magnet + Return of the next magnet will make it cancel in about ~1meter (cell length ~200 meters).
- Small $v \times B$.

B_y 10 mm above and below midplane on magnet axis (original ends, no spacer, large up-down asymmetry)

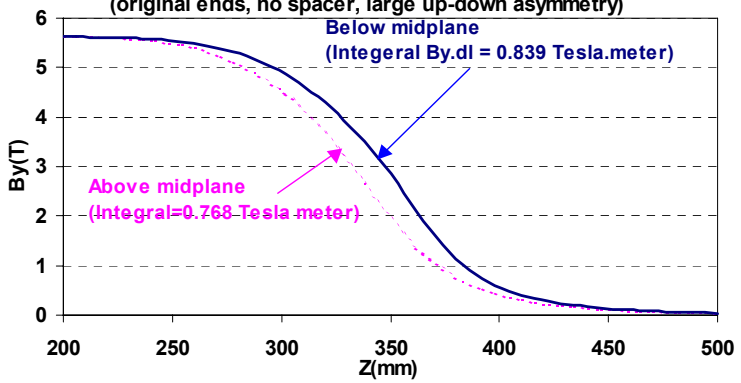

B_y 10 mm above and below midplane on magnet axis (ends optimized with one spacer to match integral)

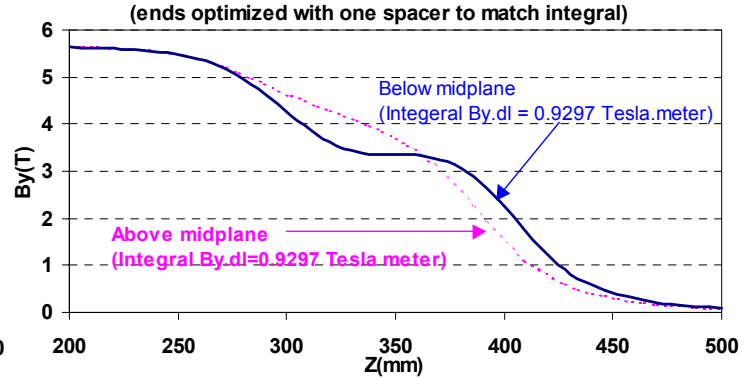

Persistent Current-induced Harmonics

(may be a problem in Nb₃Sn magnets, if nothing is done)

Nb₃Sn superconductor, with the technology under use now, is expected to generate persistent current-induced harmonics which are a factor of 10-100 worse than those measured in Nb-Ti magnets.

In addition, a snap-back problem is observed when the acceleration starts (ramp-up) after injection at steady state (constant field).

Measured sextupole harmonic in Nb-Ti magnet

Measured sextupole harmonic in Nb₃Sn magnet

Persistent current induced harmonic depends on the property of superconductor (They become small at high fields) *gupta*

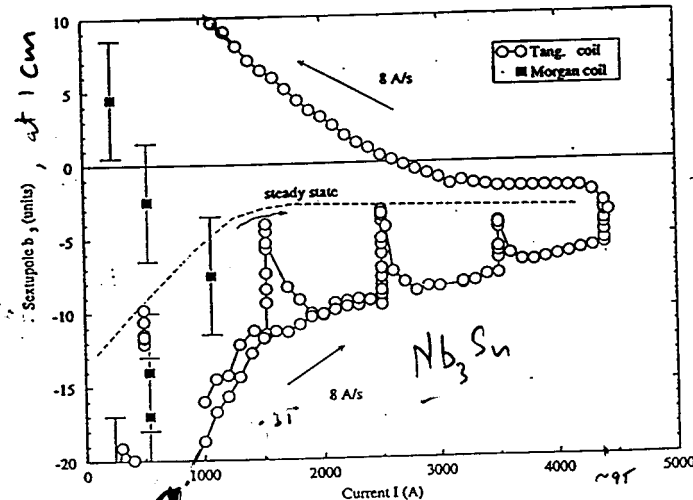
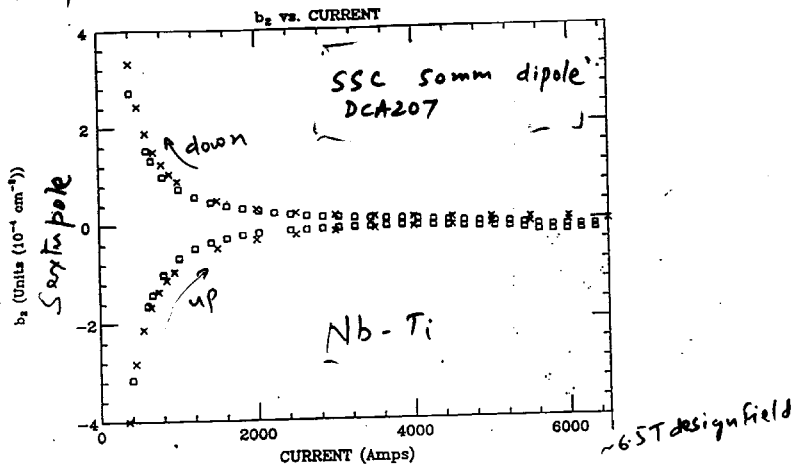

Fig. 6. Measured sextupole at low field (direction of arrow indicates up or down current).

LBL
D20 50mm
Dipole
World Record
holder: 13.5
1e6700A

Persistent Current-induced Harmonics

Superconducting
Magnet Division

Traditional solution: work on the superconductor

Persistent current induced magnetization :

$$2\mu_0 M = 2\mu_0 \frac{2}{3\pi} \nu J_c d \quad (1)$$

J_c , CRITICAL CURRENT DENSITY

d , FILAMENT DIAMETER

ν , VOL. FRACTION OF NbTi

$$M_s = M/\nu \quad (2)$$

Problem in Nb₃Sn Magnets because

- (a) J_c is higher by several times
- (b) Effective filament diameter is larger by about an order of magnitude

Conductor solution:

Reduce effective filament diameter.

A challenge; in some cases it also reduces J_c .

Measured magnetization

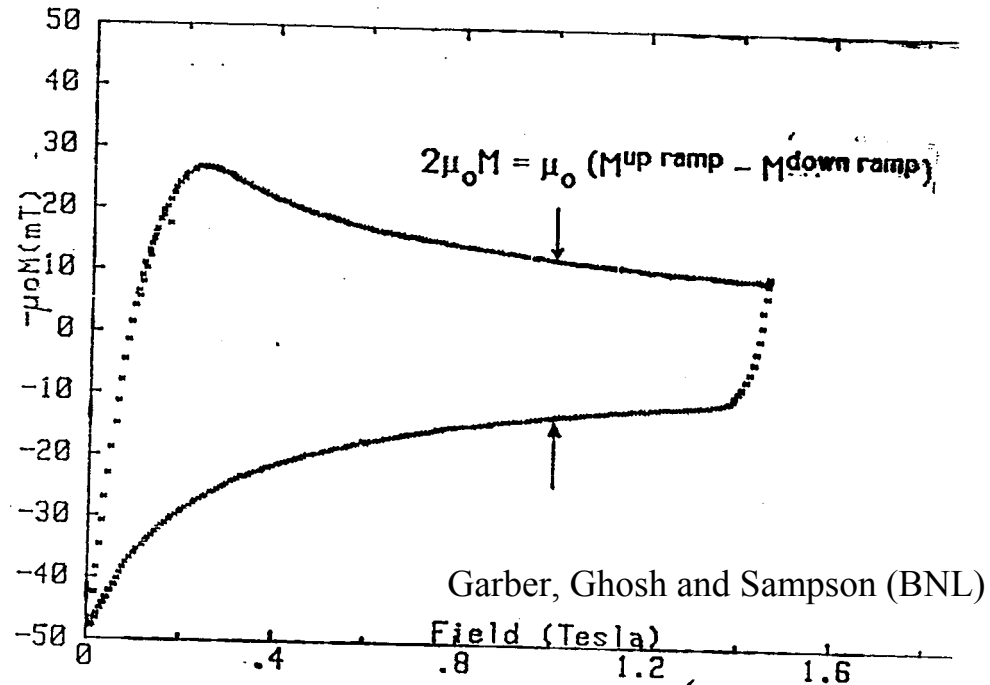

Fig. of a typical magnetization loop.

Note: Iron dominated magnets don't have this problem.

A Common Coil Magnet System for VLHC

Alternate solution: work on the magnet design: **Eliminates HEB**

**A 4-in-1
magnet for
a 2-in-1
machine**

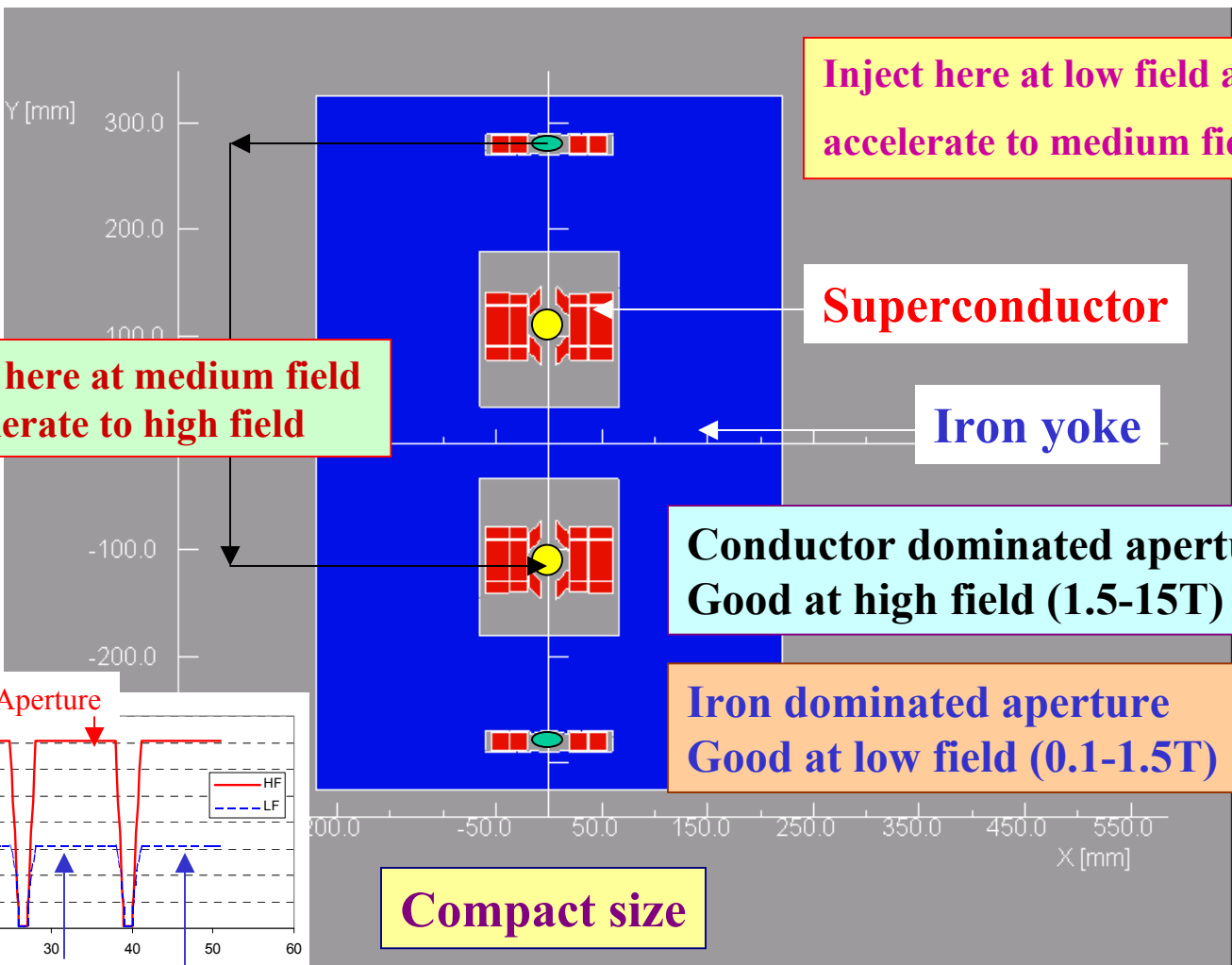

**Inject here at low field and
accelerate to medium field**

Superconductor

Iron yoke

**Transfer here at medium field
and accelerate to high field**

**Conductor dominated aperture
Good at high field (1.5-15T)**

**Iron dominated aperture
Good at low field (0.1-1.5T)**

Compact size

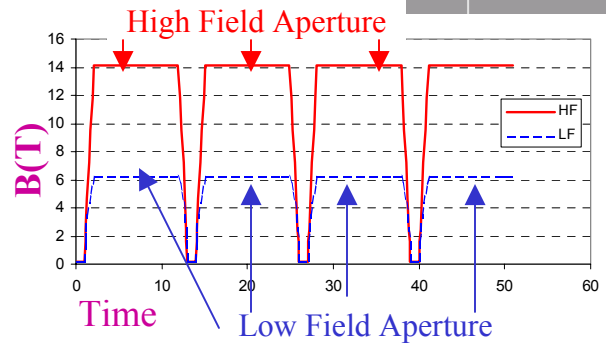

UNITS

Length	: mm
Density	: T
Length	: A m ²
Potential	: Wb m ²
Conductivity	: S m ²
Source density	: A mm ²
Power	: W
Force	: N
Energy	: J
Mass	: kg

PROBLEM DATA

Element type	: c-11-16-98-full
Element type	: ic elements
Element type	: mmetry
Element type	: otential
Element type	: ic fields
Element type	: elements
Nodes	: 91873 nodes
Regions	: 472 regions

Summary and Conclusions

- * This talk presented an understanding of field quality and a sample of a few techniques (in reality a lot more was done), which have brought a significant (both in a qualitative and in a quantitative way) advances in accelerator magnets.
- * A design and analysis approach (which some time ran against the conventional wisdom) worked well because of a systematic and experimental program.
- * From a general guideline on field quality for VLHC (in reality, it is yet to be developed and should be done in close collaboration between accelerator physicists and magnet scientists), it appears that all magnet designs should be useable in VLHC from field quality point of view. The question is cost.
- * A consistently good field quality, however should not take it for granted. It is usually a result of several things (a good design, engineering, measurements, manufacturing and vigilance, etc.).
- * We should examine if magnet costs can be significantly reduced by relaxing parts and manufacturing tolerances. Given the time available for the next machine this is the time to explore the ways for reducing magnet costs while maintaining a field quality that is acceptable for VLHC .