

# Unique Common Coil Test Facility (CCTF) Based on the BNL Common Coil Dipole for Cable and Coil Testing at High Fields

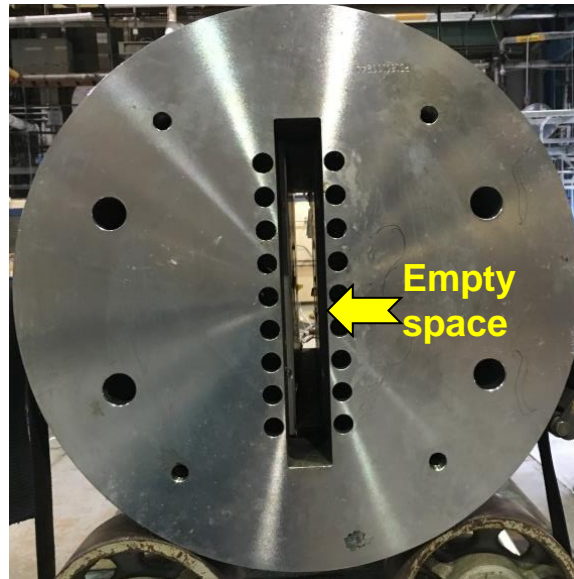

**Prepared by Ramesh Gupta for  
Superconducting Magnet Division @ BNL**

# A Unique Background-field Dipole

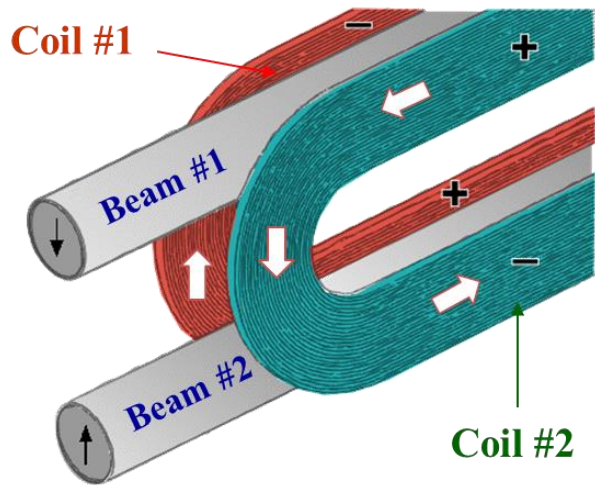

- **Nb<sub>3</sub>Sn, 2-in-1, common coil dipole**
- **Structure specifically designed to provide a large open space (31mm wide, 335mm high)**
- **New racetrack coils can be inserted here for testing them in a background field of ~10 T**
- **These new insert coils come in direct contact with the existing Nb<sub>3</sub>Sn coils and become an integral part of a potential ~16 T dipole**
- **A new coil test becomes a new magnet test**
- **Allows a rapid-turn around, low-cost test**
- **A unique facility for testing HTS cables also**

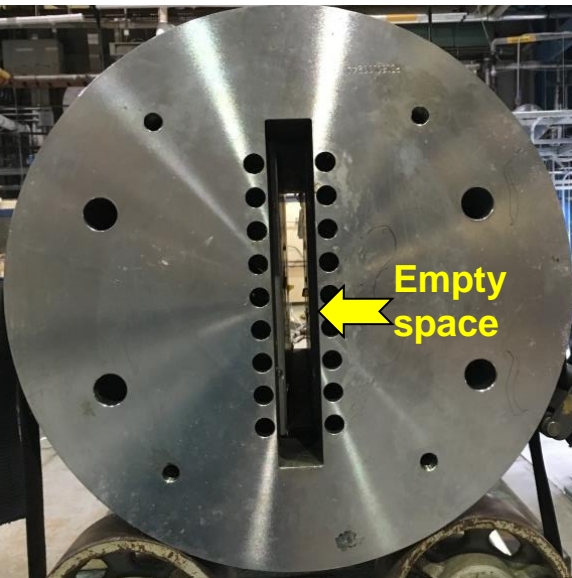

# Rapid turn-around, Low cost R&D Approach

## Five Simple Steps/Components

1. Magnet (dipole) with a large open space
2. Coil for high field testing
3. Slide coil in the magnet
4. Coils become an integral part of the magnet
5. Magnet with new coil(s) ready for testing

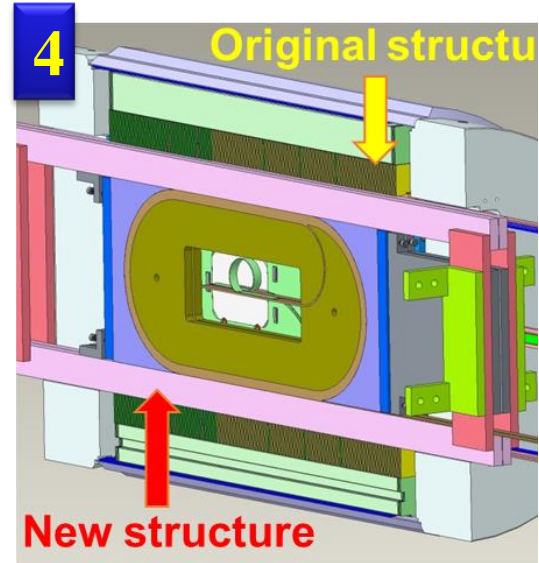
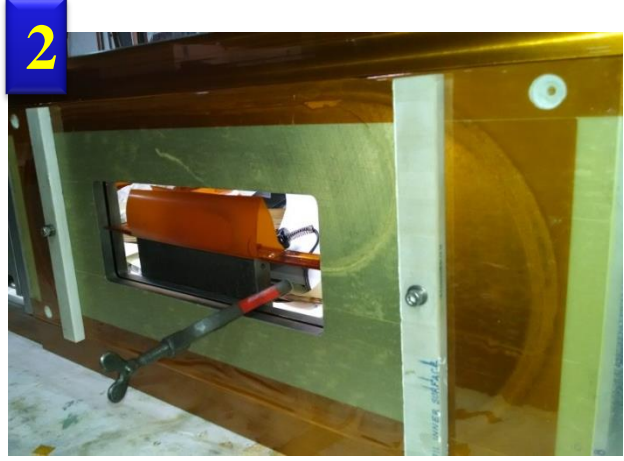
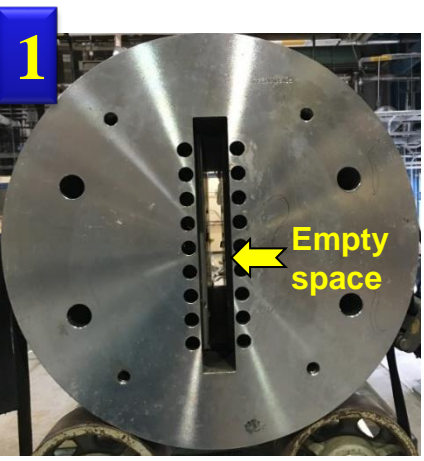

# Basic Parameters of Dipole DCC017

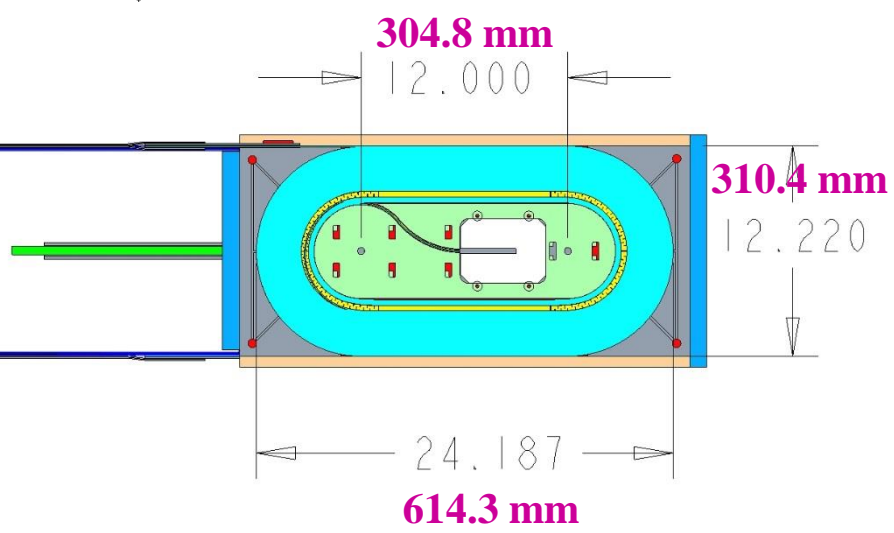
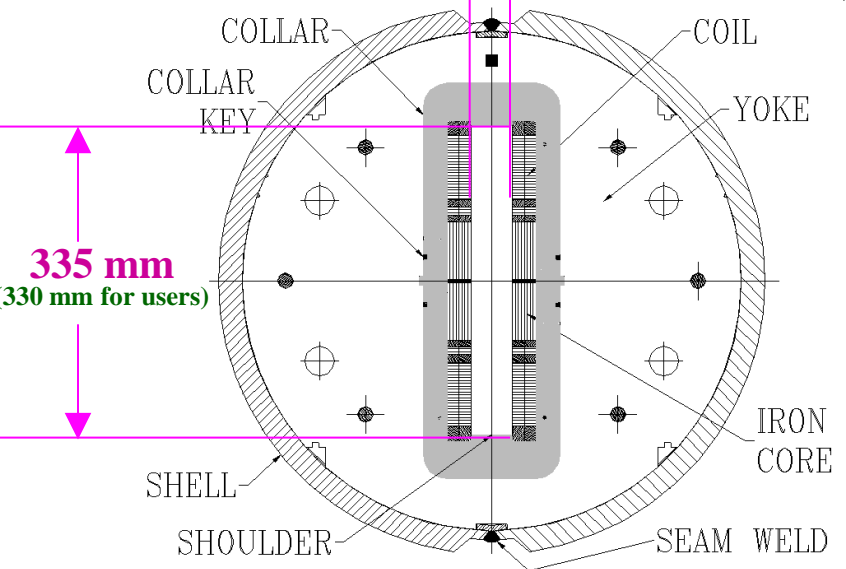

- Two layer, 2-in-1 common coil design
- 10.2 T bore field, 10.7 T peak field at 10.8 kA short sample current
- **31 mm (use 29 mm) horizontal aperture**
- **335 mm (use 330 mm) vertical aperture**
  - **A unique feature for testing insert coils or cables**
- **977 mm magnet length (overall)**
- **305 mm coil straight section**
- 0.8 mm, 30 strand Rutherford cable
- 70 mm minimum bend radius
- 85 mm coil height
- 614 mm coil length
- 653 mm yoke length One spacer in body and one in ends
- Iron bobbin
- Stored Energy@Quench ~0.2 MJ

# Detailed Design Parameters of DCC017

## Superconducting Magnet Division

### MAJOR PARAMETERS OF REACT & WIND COMMON COIL DIPOLE DCC017

Magnet design	2-in-1 common coil dipole with racetrack coils
Conductor type	Nb <sub>3</sub> Sn
Magnet technology	React and wind
Horizontal coil aperture (clear space)	31 mm
Vertical coil aperture (clear space)	335 mm
Separation between the magnetic center of the upper and lower aperture	236 mm
Number of layers	Two
Number of turns per quadrant of single aperture (pole-to-pole)	45 turns in each layer
Coil height (pole-to-pole)	85 mm
Wedge(s) (size and number)	8.5 mm, one in each layer (inner & outer)
End-spacer(s) (size and number)	8.5 mm, one in each layer (inner & outer)
Wire non-Cu J <sub>sc</sub> (4.2 K, 12 T)	1900 A/mm <sup>2</sup>
Strand diameter	0.8 mm
Number of strands in inner and outer cable	30
Cable width (inner and outer layers)	13.13 mm
Cu/Non-Cu ratio in the wire (same for both inner and outer cables)	1.53
Computed quench current (limited by inner)	10.8 kA
Computed quench field @4.2 K	10.2 T
Peak field at quench in inner, outer Layer	10.7 T, 6.1 T
Special electrical feature (not used)	Shunt between layers
Computed stored energy at quench	0.2 MJ
Computed inductance	4.9 mH
Coil bobbin (core) material	Carbon steel
Coil length (overall)	614.3 mm
Coil straight section length	304.8 mm
Coil height (overall)	310.4 mm
Coil inside radius in ends	70 mm
Coil outside radius in ends	155 mm
Coil curing preload - sides	0 N
Coil curing preload - ends	0 N
Insulation thickness between turns	180 μm thick Nomex®
Potting agent	CTD-101K
Thickness of the collar	26.6 mm
Thickness of stainless-steel sheet between inner and outer layers	1.65 mm
Vertical pre-stress applied	17 MPa (low)
Horizontal pre-stress applied	Essentially none
Computed horizontal stress on structure	59 MPa at 10.2 T
Design maximum for horizontal stress	75 MPa
Stainless steel shell thickness	25.4 mm
Thickness of the end plates	127 mm
Yoke outer radius	267 mm
Yoke length	653 mm
Quench protection strip heaters (no energy extraction available during the tests)	25 μm X 38.1 mm, each quadrant, between layers

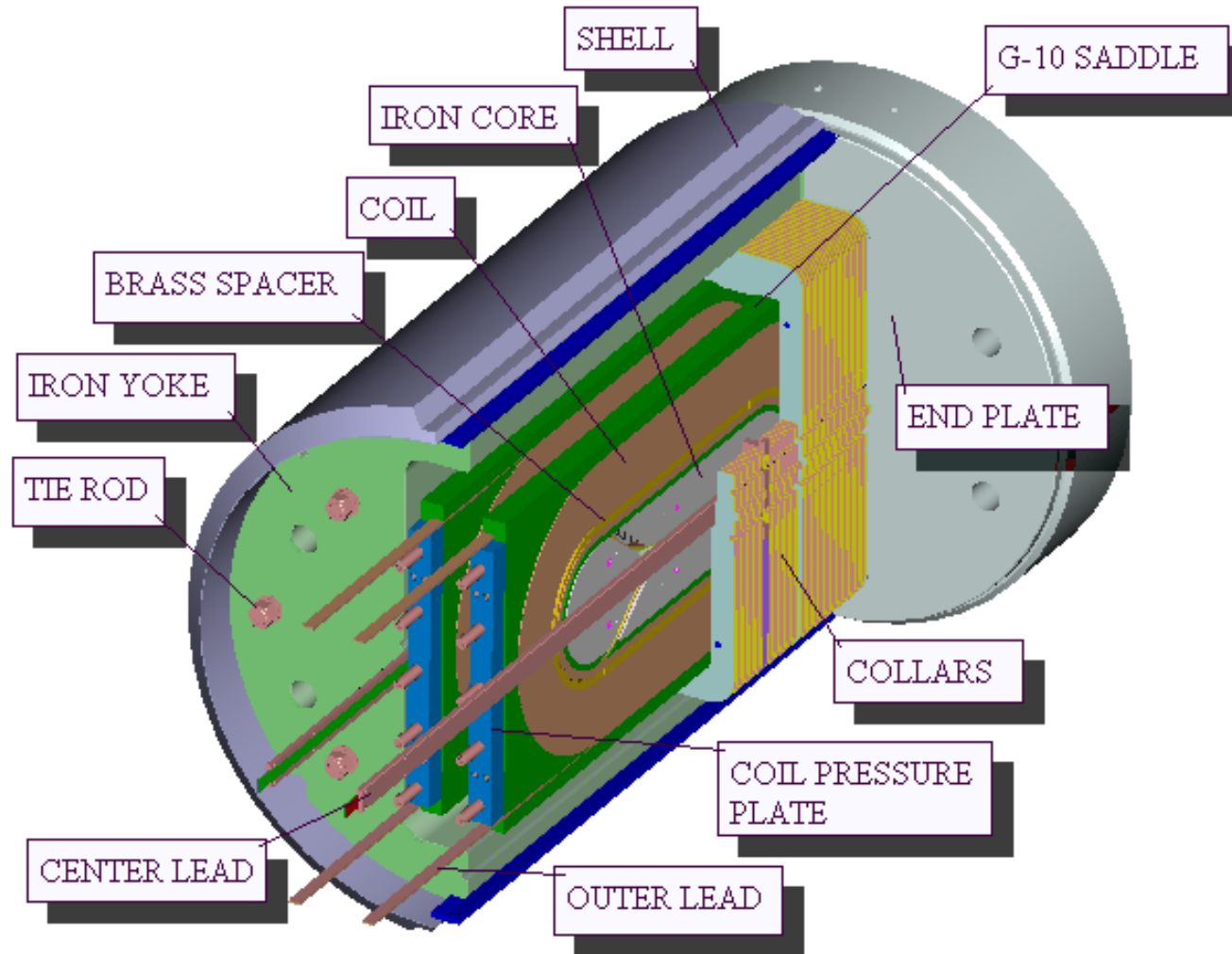

# Space Restrictions



10-18-2021

Common Coil Aperture Size

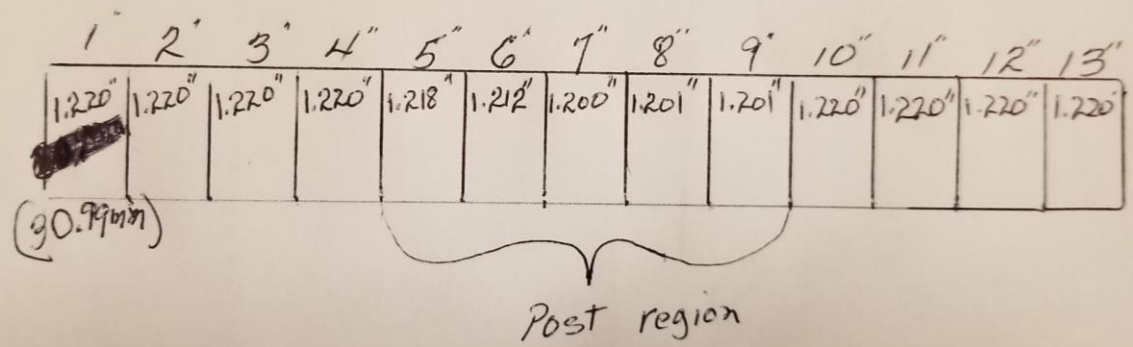

1" to 13" are only accessible from below.



# Nb<sub>3</sub>Sn Coil Package of DCC017

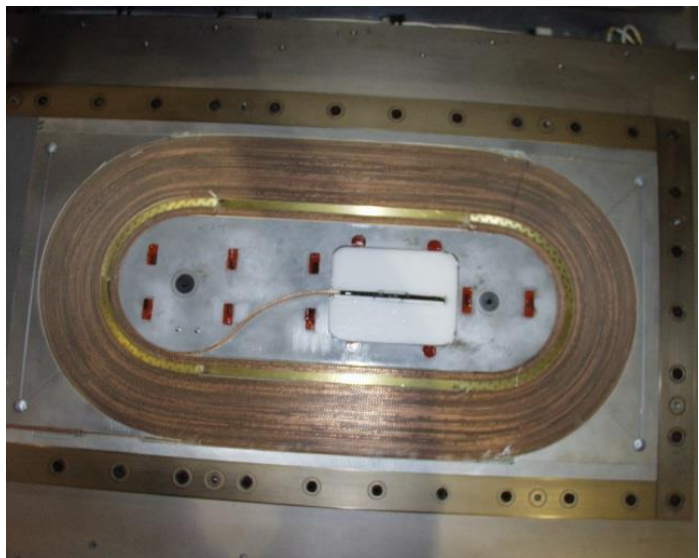
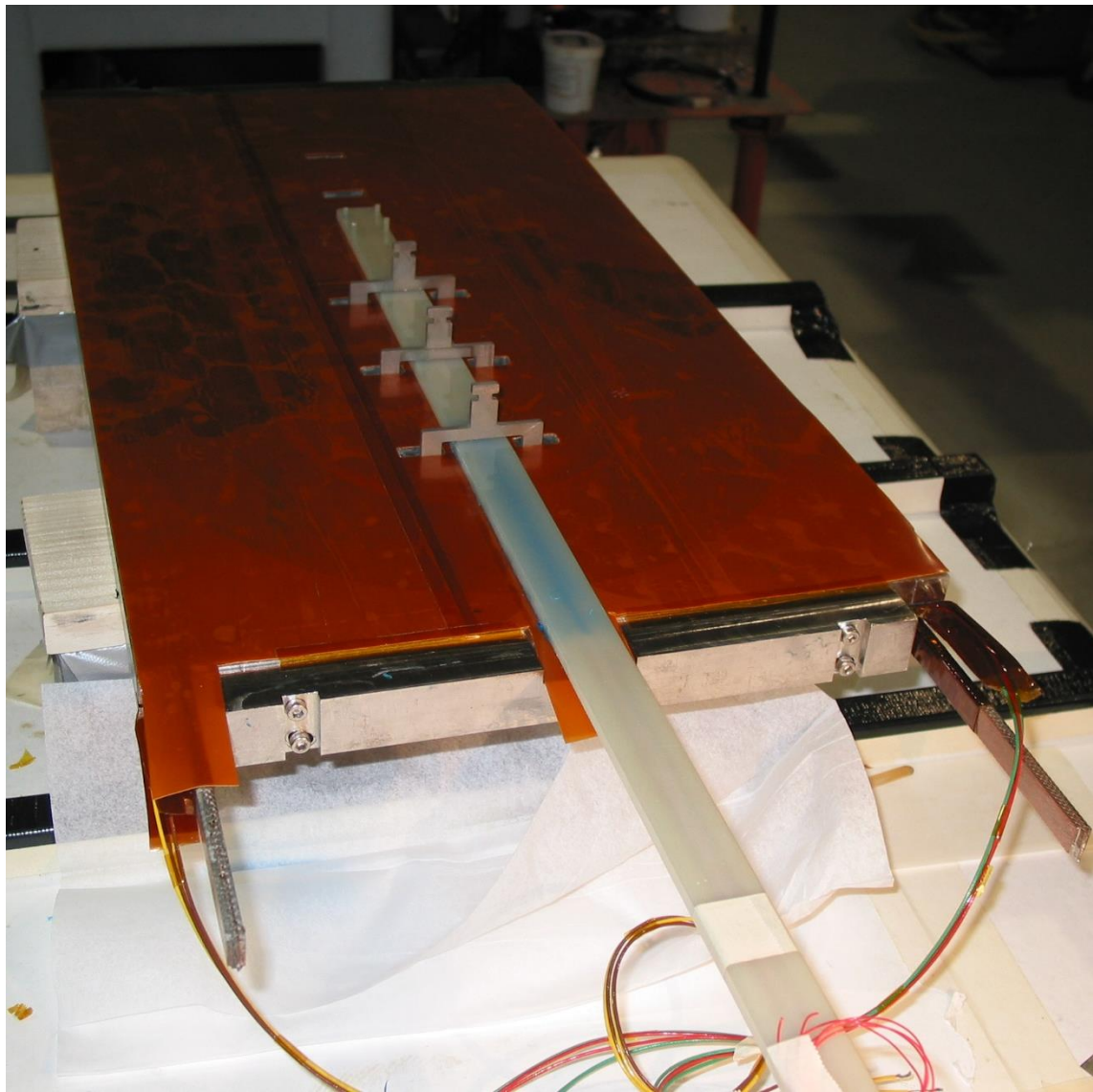
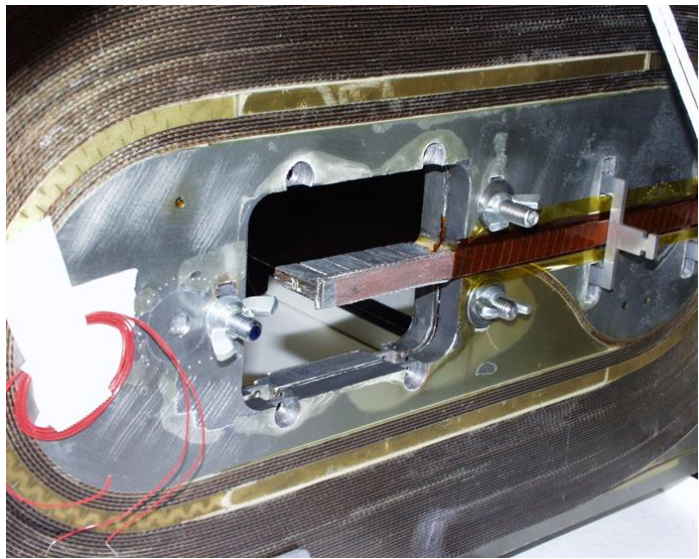



# HTS/LTS Hybrid Dipole & Cable Test (2019) (an example of four tests in one run)

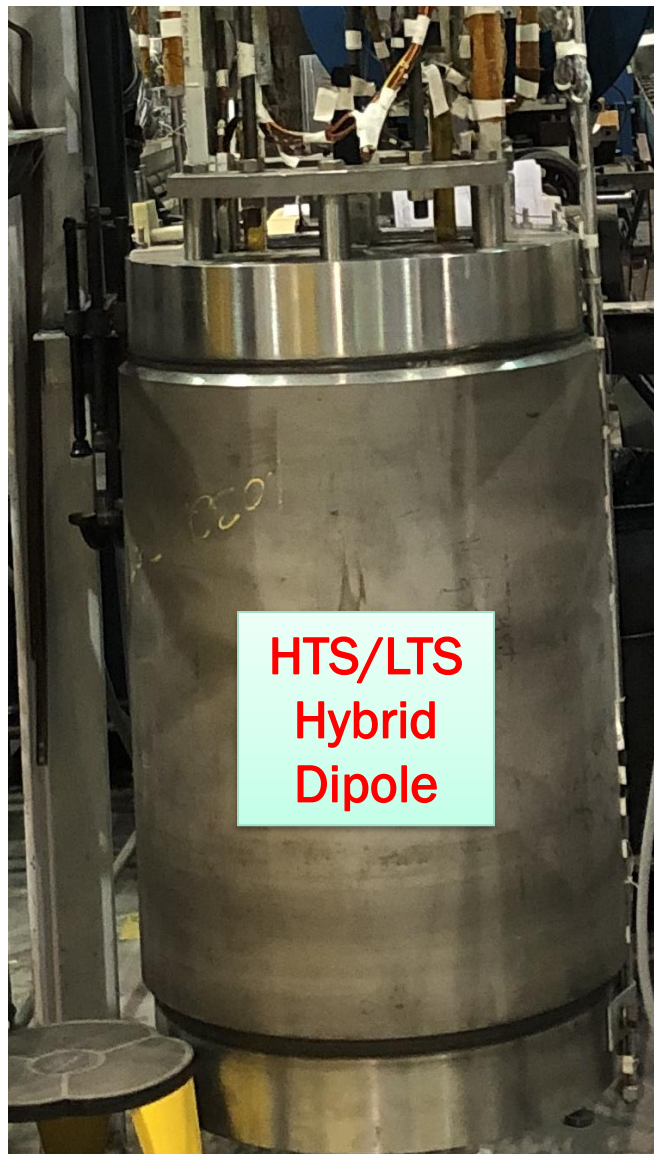

HTS/LTS  
Hybrid  
Dipole

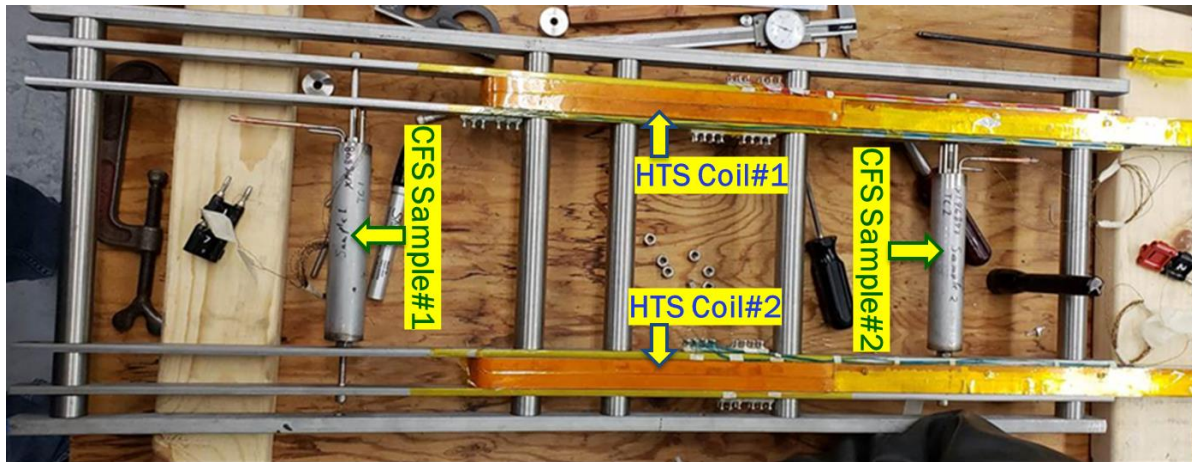
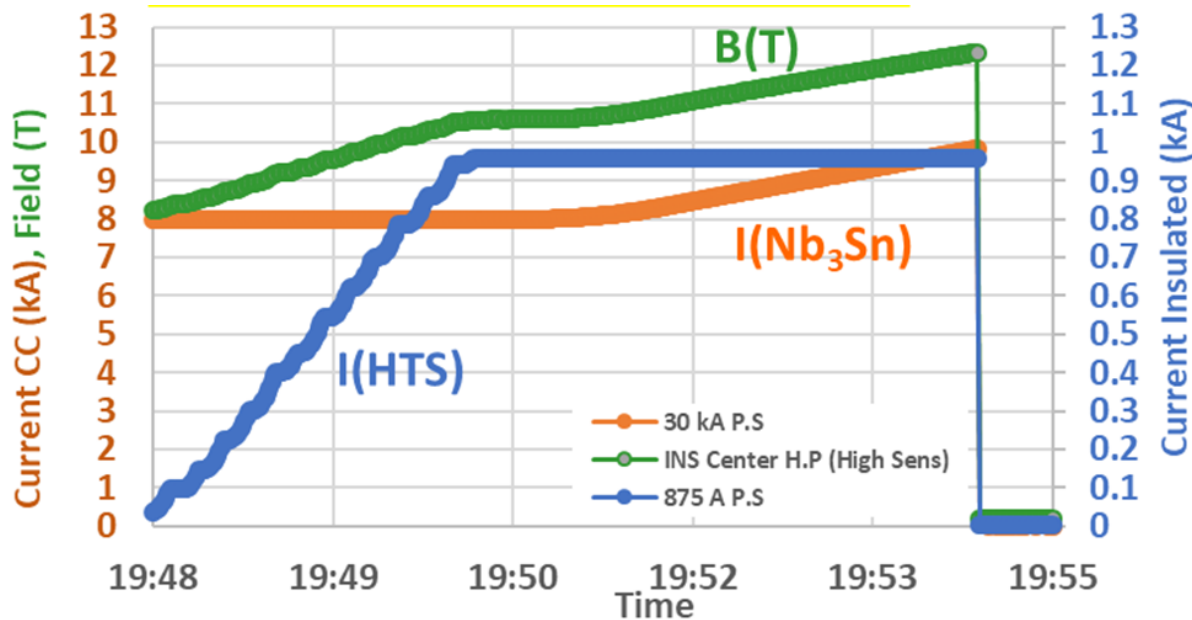

# HTS/LTS Hybrid Dipole Test (2016)

(new HTS insert coils with existing Nb<sub>3</sub>Sn magnet coil)

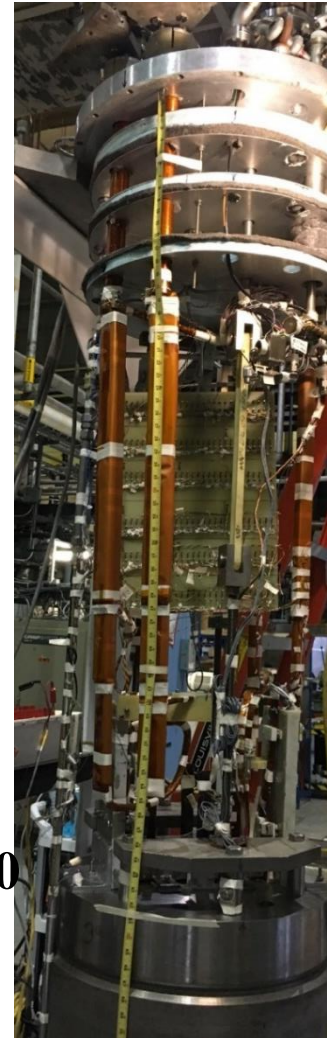
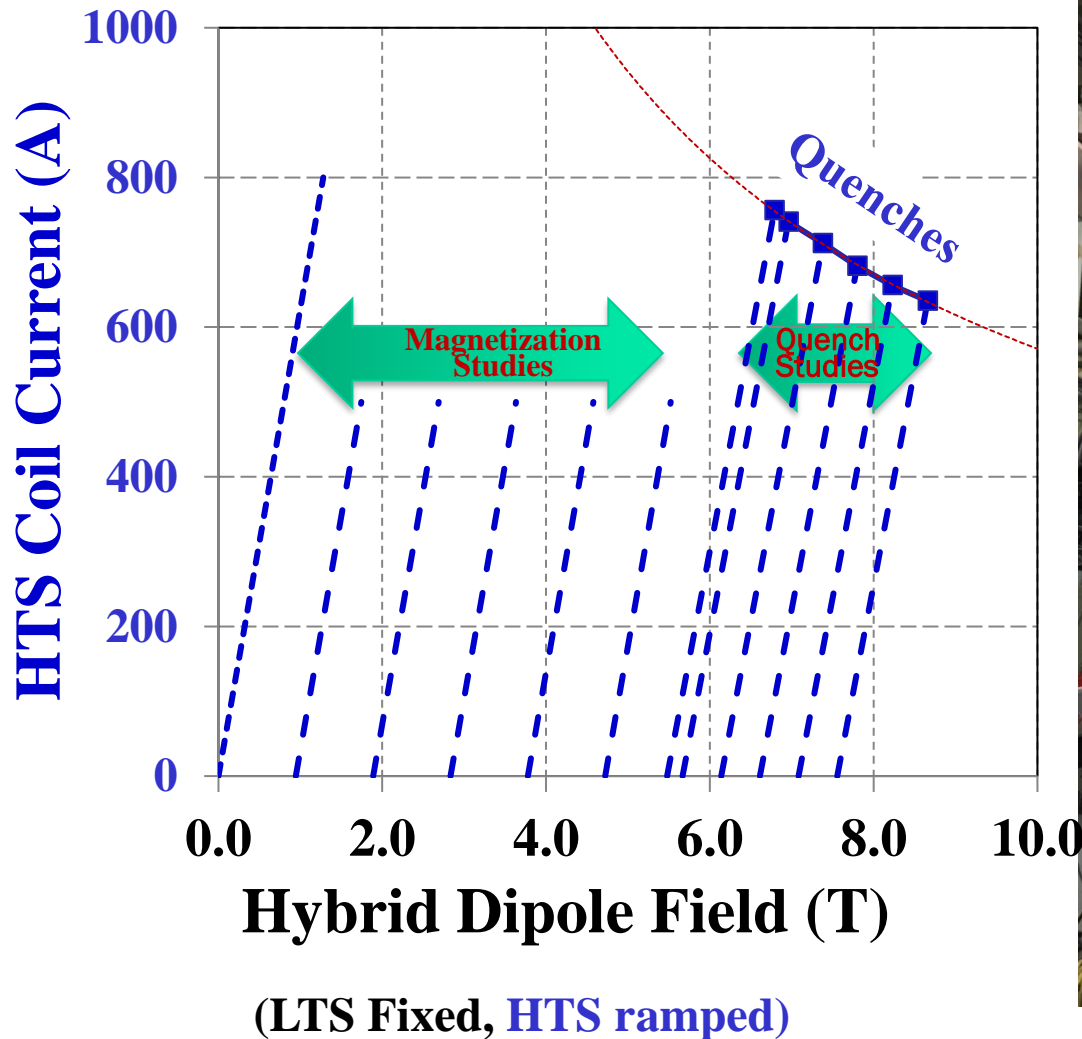

HTS coils were ramped to quench, just like LTS coils

HTS coils exhibited NO training and NO degradation despite a number of quenches

# Quench Protection of HTS Coils in HTS/LTS Hybrid Magnet (2016)

**HTS coils were operated like the LTS coils**  
(significant voltages allowed till quench even on the HTS coils)

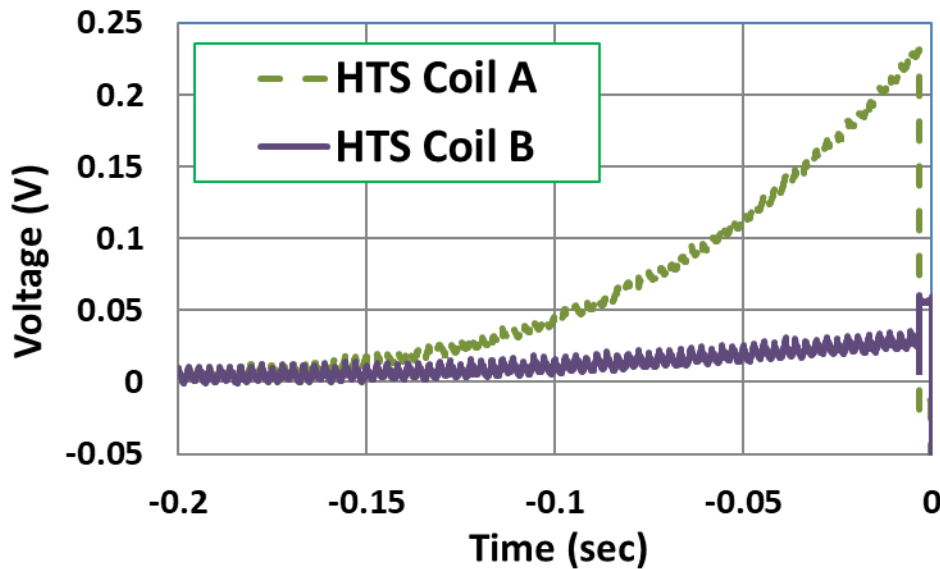

**HTS and LTS coils were operated with different power supplies and had separate energy extraction under a common platform**

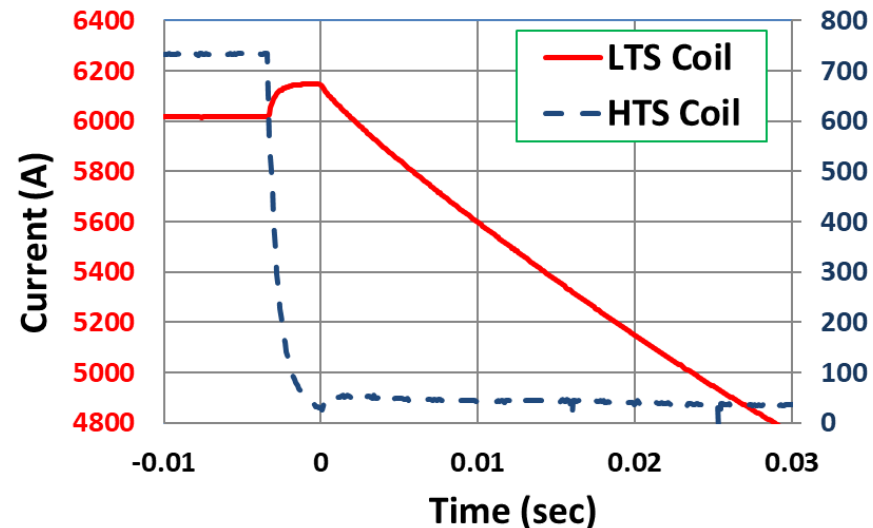
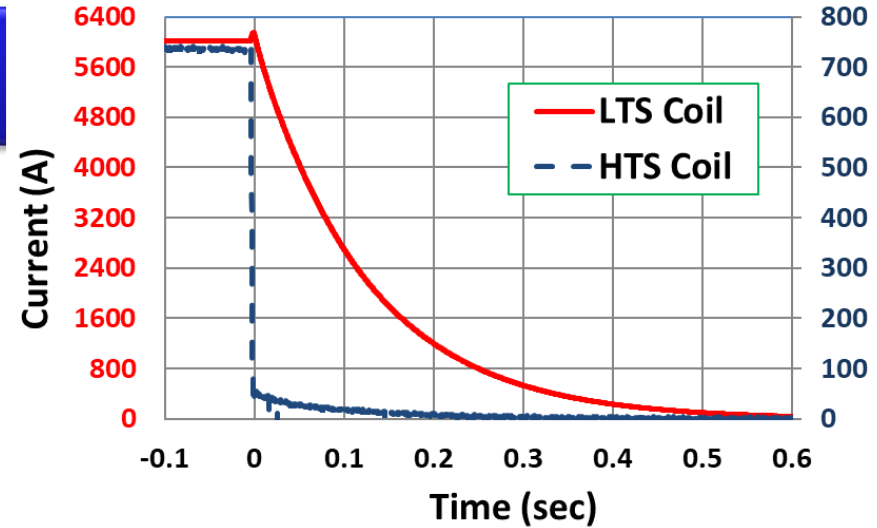

# 2-d Magnetic Model

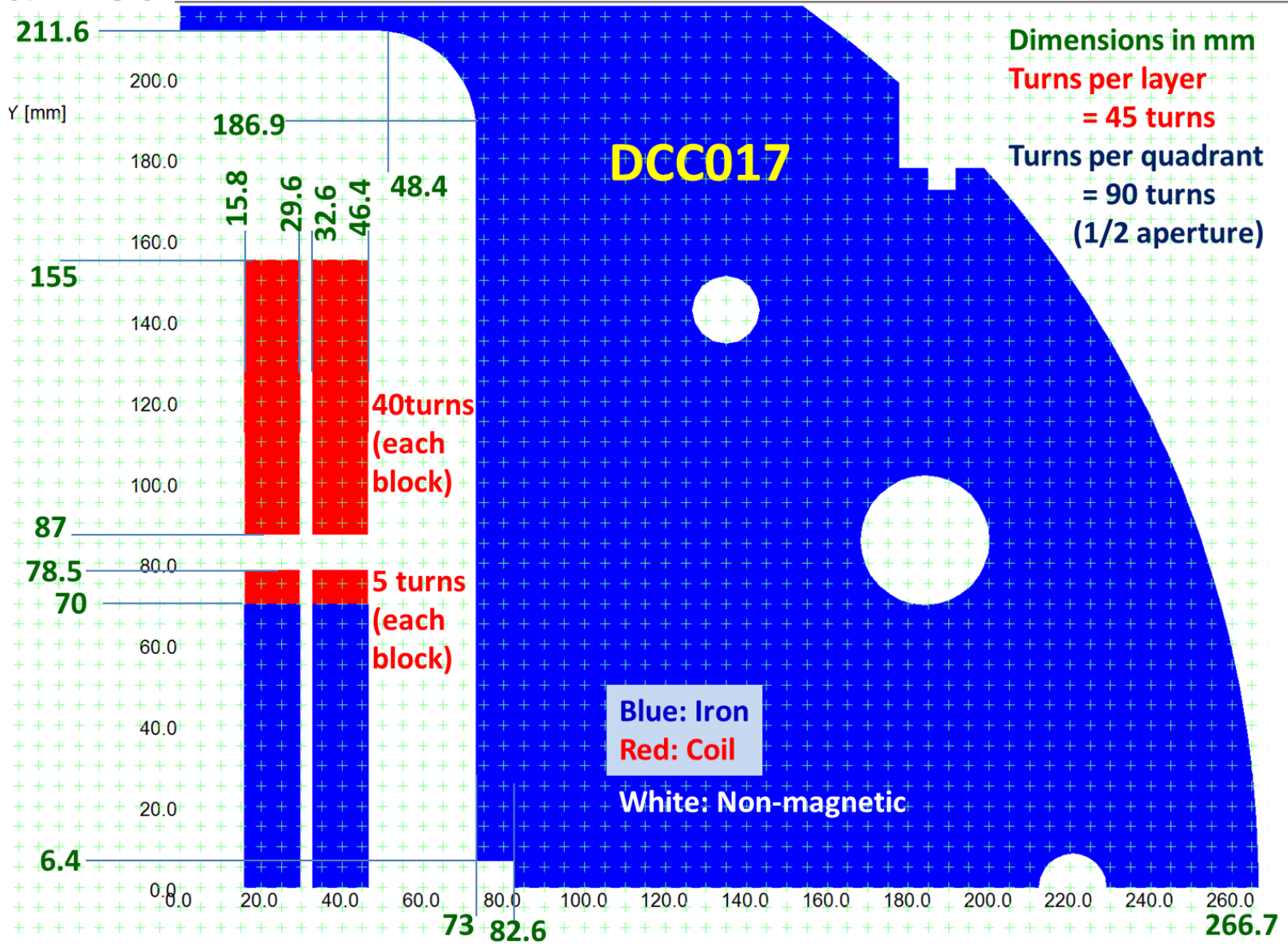

# 3d-model and the Field Profile inside DCC017

# 3-d model of the coils with $\frac{3}{4}$ cut-out of the iron yoke

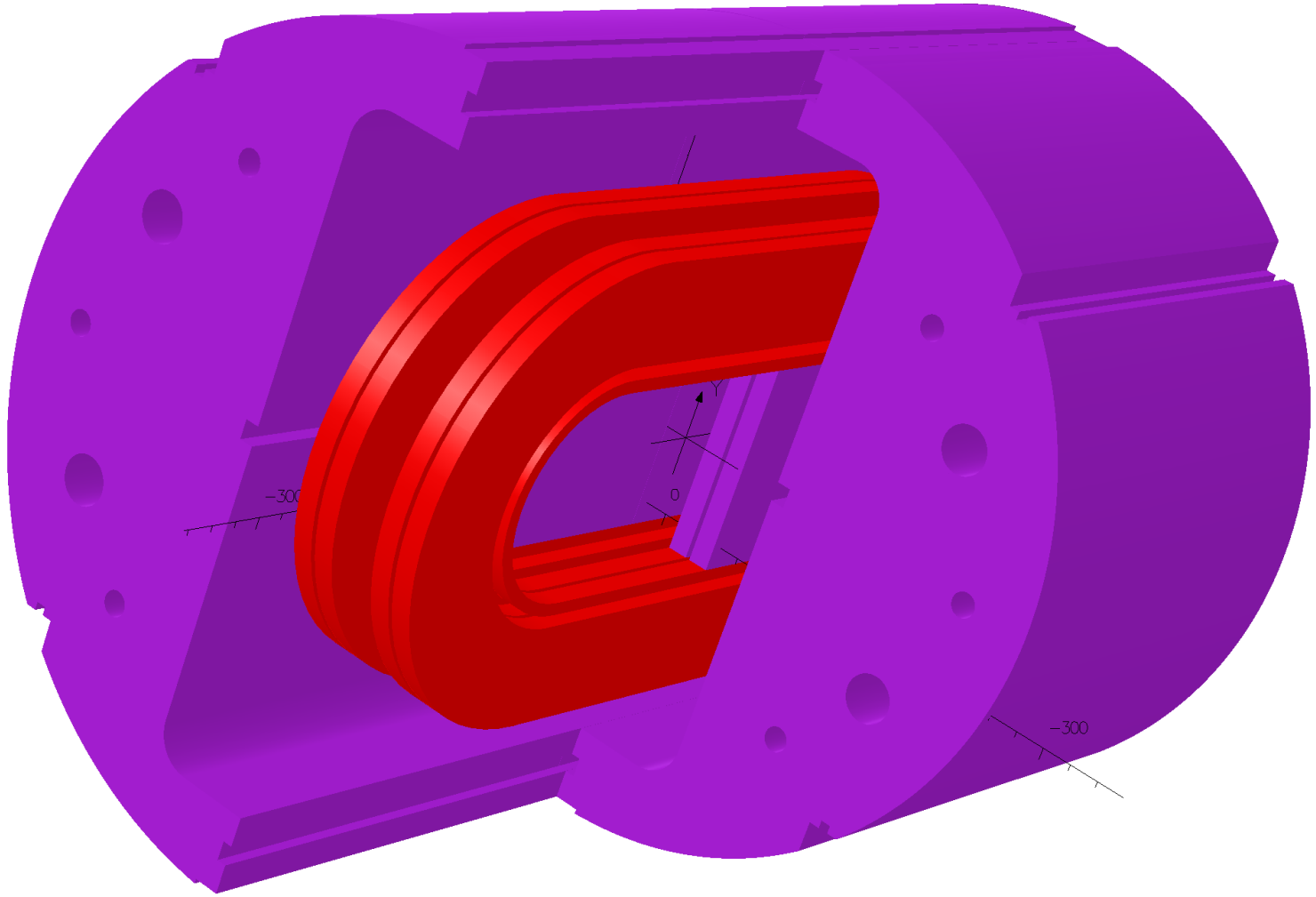

UNITS	
Length	mm
Magn Flux Density	T
Magn Field	A m <sup>-1</sup>
Magn Scalar Pot	A
Magn Vector Pot	Wb m <sup>-1</sup>
Elec Flux Density	Cm <sup>-1</sup>
Elec Field	V m <sup>-1</sup>
Conductivity	S mm <sup>-1</sup>
Current Density	A mm <sup>-2</sup>
Power	W
Force	N
Energy	J
Mass	kg

MODEL DATA	
dc017-no-ns-usmdp.op3	
TOSCA Magnetostatic	
Nonlinear materials	
Simulation No 1 of 1	
47698232 elements	
9484251 nodes	
8 conductors	
Nodally interpolated fields	
Activated in global coordinates	
Reflection in XZ plane (Z field=0)	
Reflection in YZ plane (X field=0)	

  

Field Point Local Coordinates	
Local	= global

# Magnitude of the Field in DCC017 at $x=0$ ( $y-z$ plane)

13/Sep/2019 11:48:44

Map contours: B

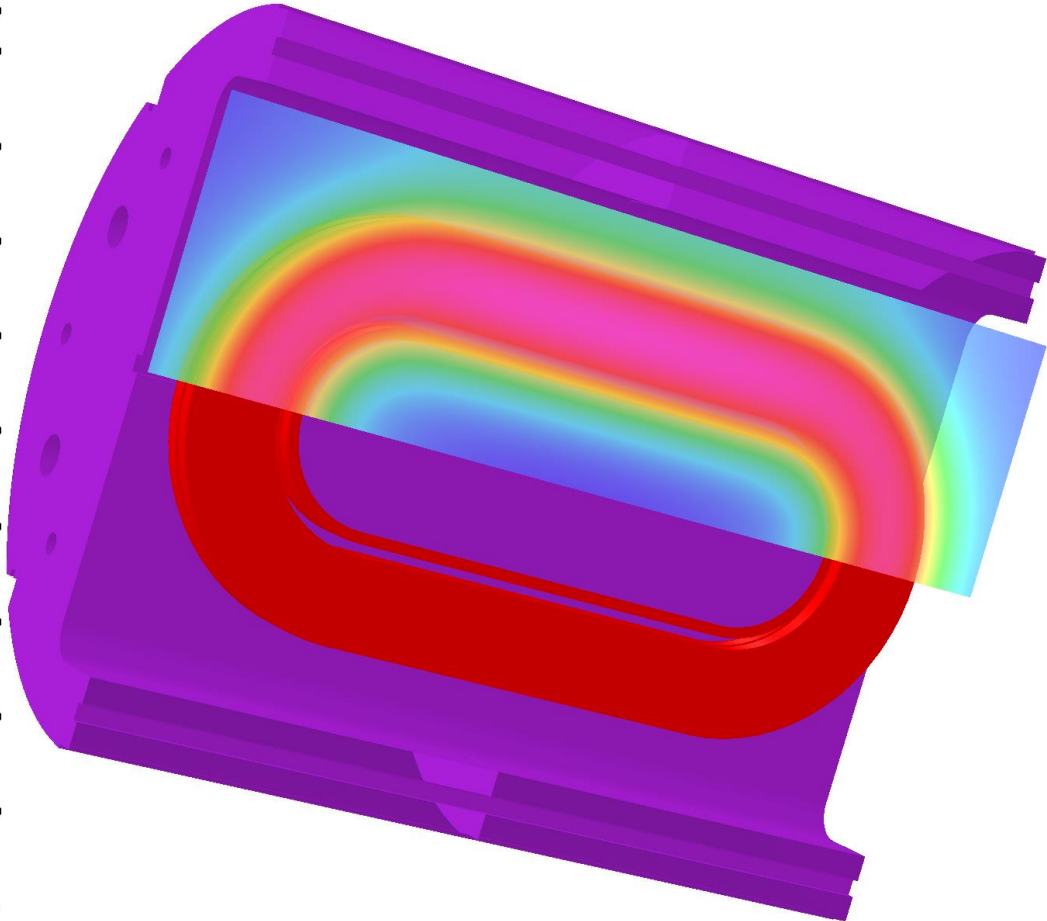
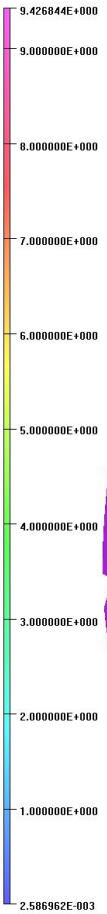

Integral = 6.487019E+005

UNITS	
Length	mm
Magn Flux Density	T
Magn Field	A m <sup>-1</sup>
Magn Scalar Pot	A
Magn Vector Pot	Wb m <sup>-1</sup>
Elec Flux Density	C m <sup>-2</sup>
Elec Field	V m <sup>-1</sup>
Conductivity	S mm <sup>-1</sup>
Current Density	A mm <sup>-2</sup>
Power	W
Force	N
Energy	J
Mass	kg

MODEL DATA	
dcc017-no-ins-usmdp.op3	
TOSCA Magnetostatic	
Nonlinear materials	
Simulation No 1 of 1	
47698232 elements	
9454251 nodes	
8 conductors	
Nodally interpolated fields	
Activated in global coordinates	
Reflection in XY plane (Z field=0)	
Reflection in YZ plane (X field=0)	

FIELD POINT Local Coordinates	
Local = Global	

FIELD EVALUATIONS		
Cartesian CARTESIAN (nodal)	100x100	Cartesian
x=0.0	y=0.0 to 200.0	z=-350.0 to 350.0

**@10 kA**

Opera

# Direction of the Field between the Coils in the Open Space of DCC017

Surface contours: B

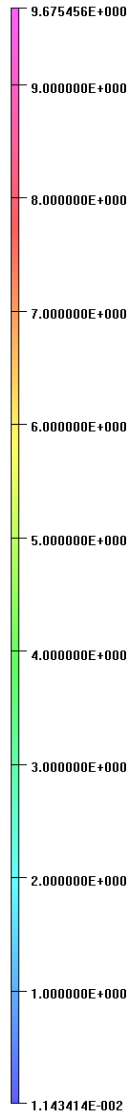

**DCC017**  
(magnet only)

**@ 10 kA**

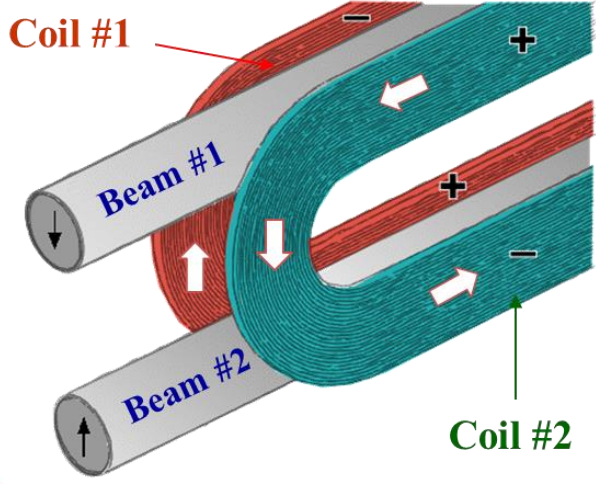
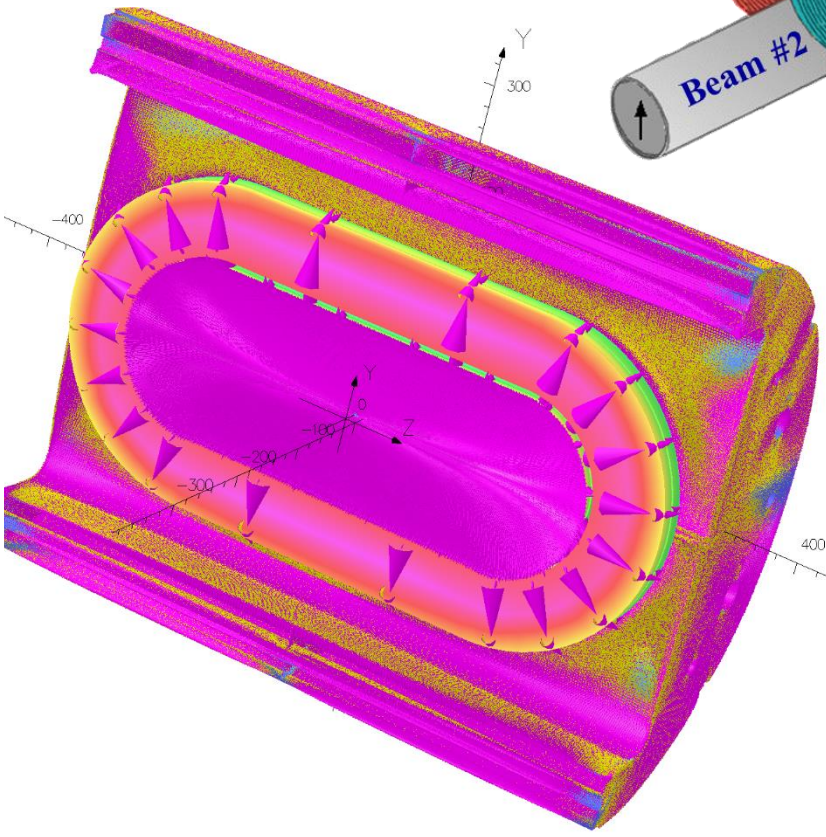

**DCC017**  
(with an insert coil)

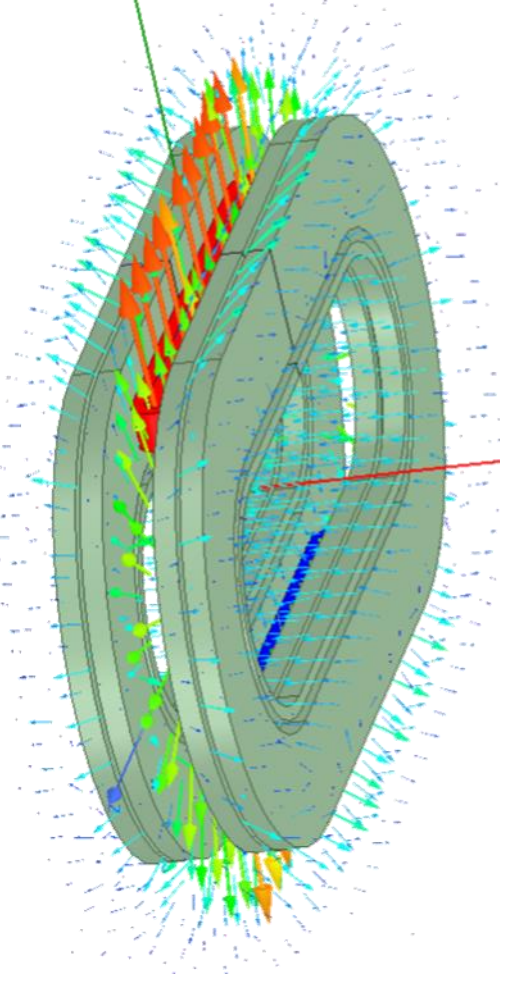

**COMSOL**

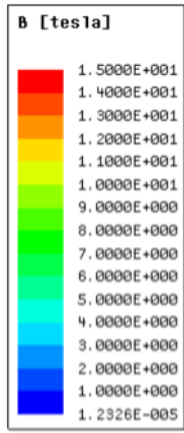



**$B_y$  along the Vertical-axis at  $x=0, z=0$**

**@ 10 kA**

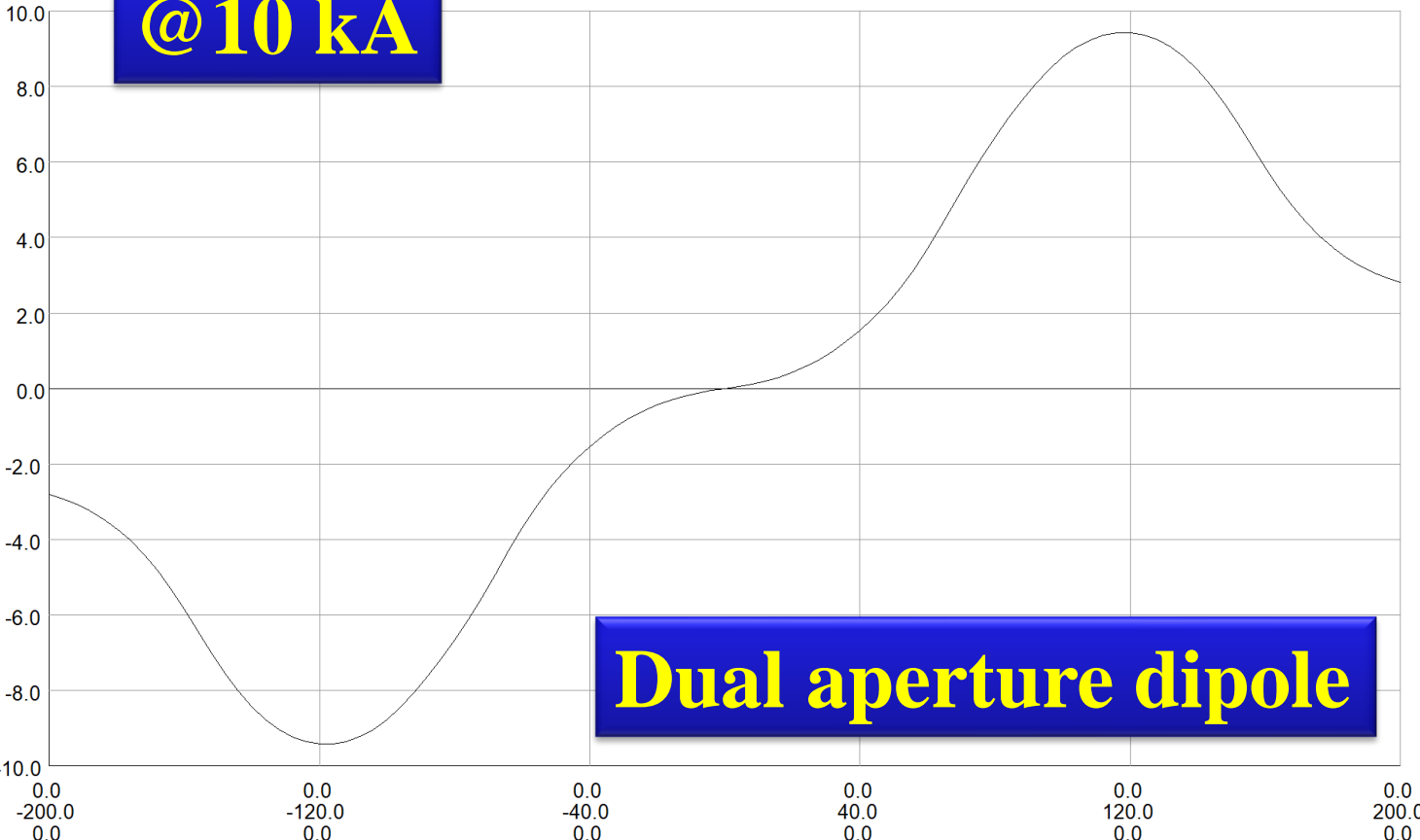

X coord 0.0 0.0 0.0 0.0 0.0 0.0  
 Y coord -200.0 -120.0 -40.0 0.0 40.0 120.0 200.0  
 Z coord 0.0 0.0 0.0 0.0 0.0 0.0 0.0

Component: BY, from buffer: Line, Integral = 0.0208363806530265

UNITS	
Length	mm
Magn Flux Density	T
Magn Field	A m <sup>-1</sup>
Magn Scalar Pot	A
Magn Vector Pot	Vb m <sup>-1</sup>
Elec Flux Density	C m <sup>-2</sup>
Elec Field	V m <sup>-1</sup>
Conductivity	S mm <sup>-1</sup>
Current Density	A mm <sup>-2</sup>
Power	W
Force	N
Energy	J
Mass	kg

MODEL DATA	
dcc017-no-ins-usmdp.ap3	
TOSCA Magnetostatic	
Nonlinear materials	
Simulation No 1 of 1	
47698232 elements	
945431 nodes	
8 conductors	
Nodally interpolated fields	
Activated in global coordinates	
Reflection in XY plane (Z field=0)	
Reflection in YZ plane (X field=0)	

FIELD POINT Local Coordinates	
Local = Global	

FIELD EVALUATIONS		
Line LINE (nodal) 101	Cartesian	
x=0.0	y=-200.0 to 200.0	z=0.0

**B along the y-axis at x=0, z=0 (upper bore)**

6/Aug/2019 10:23:23

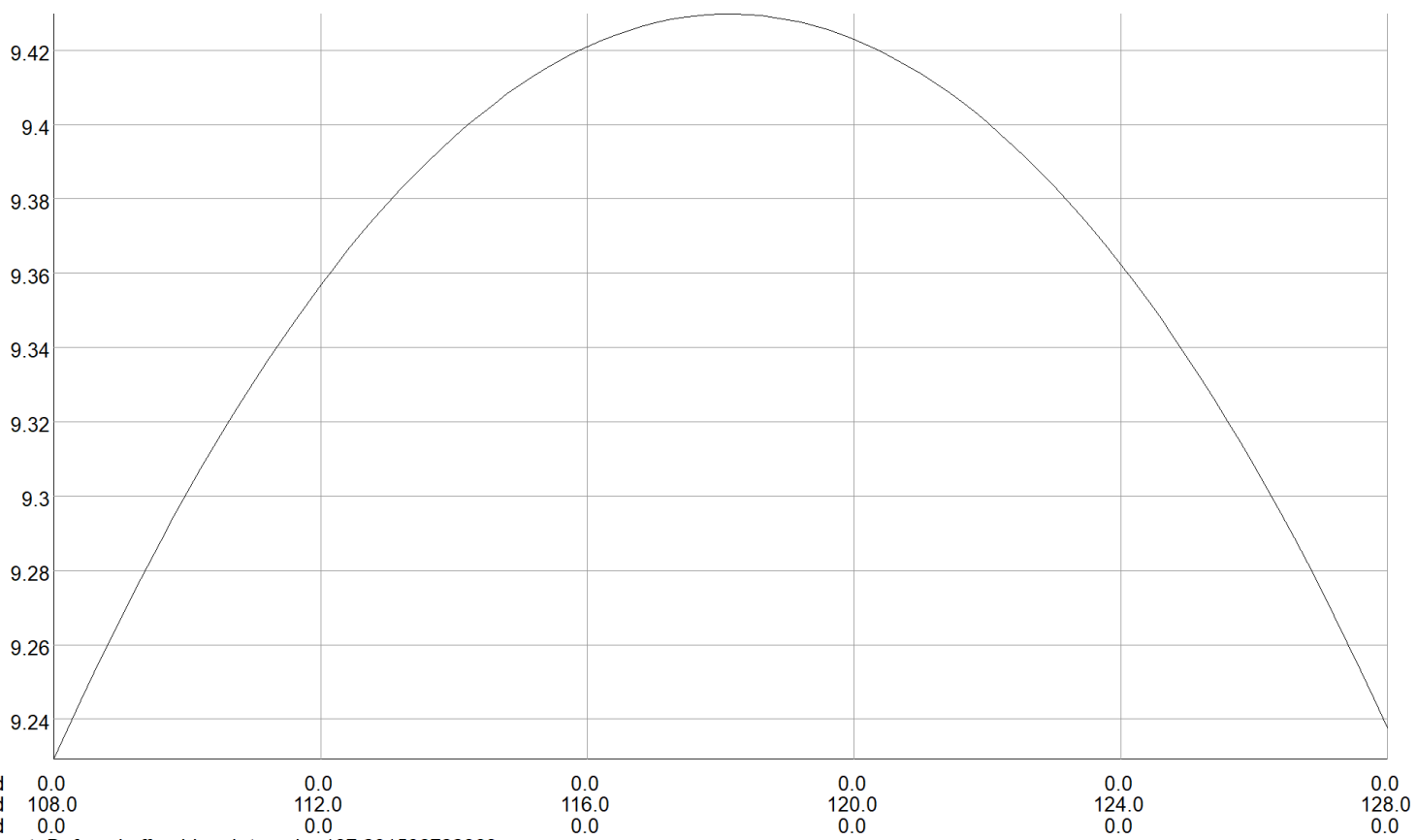

**UNITS**  
 Length mm  
 Magn Flux Density T  
 Magn Field A m<sup>-1</sup>  
 Magn Scalar Pot A  
 Magn Vector Pot Wb m<sup>-1</sup>  
 Elec Flux Density C m<sup>-2</sup>  
 Elec Field V m<sup>-1</sup>  
 Conductivity S mm<sup>-1</sup>  
 Current Density A mm<sup>-2</sup>  
 Power W  
 Force N  
 Energy J  
 Mass kg

**MODEL DATA**  
 dcc017-no-ins-usmdp.op3  
 TOSCA Magnetostatic  
 Nonlinear materials  
 Simulation No 1 of 1  
 47698232 elements  
 9454251 nodes  
 8 conductors  
 Nodally interpolated fields  
 with B and H by integration  
 Activated in global coordinates  
 Reflection in XY plane (Z field=0)  
 Reflection in YZ plane (X field=0)

**Field Point Local Coordinates**  
 Local = Global

**FIELD EVALUATIONS**  
 Line L:HE (nodal+inte) 101 Cartesian  
 x=0.0 y=108.0 to 128.0 z=0.0

Component: B, from buffer: Line, Integral = 187.291536722363

**@10 kA**

Opera

# B along the z-axis (center of upper bore)

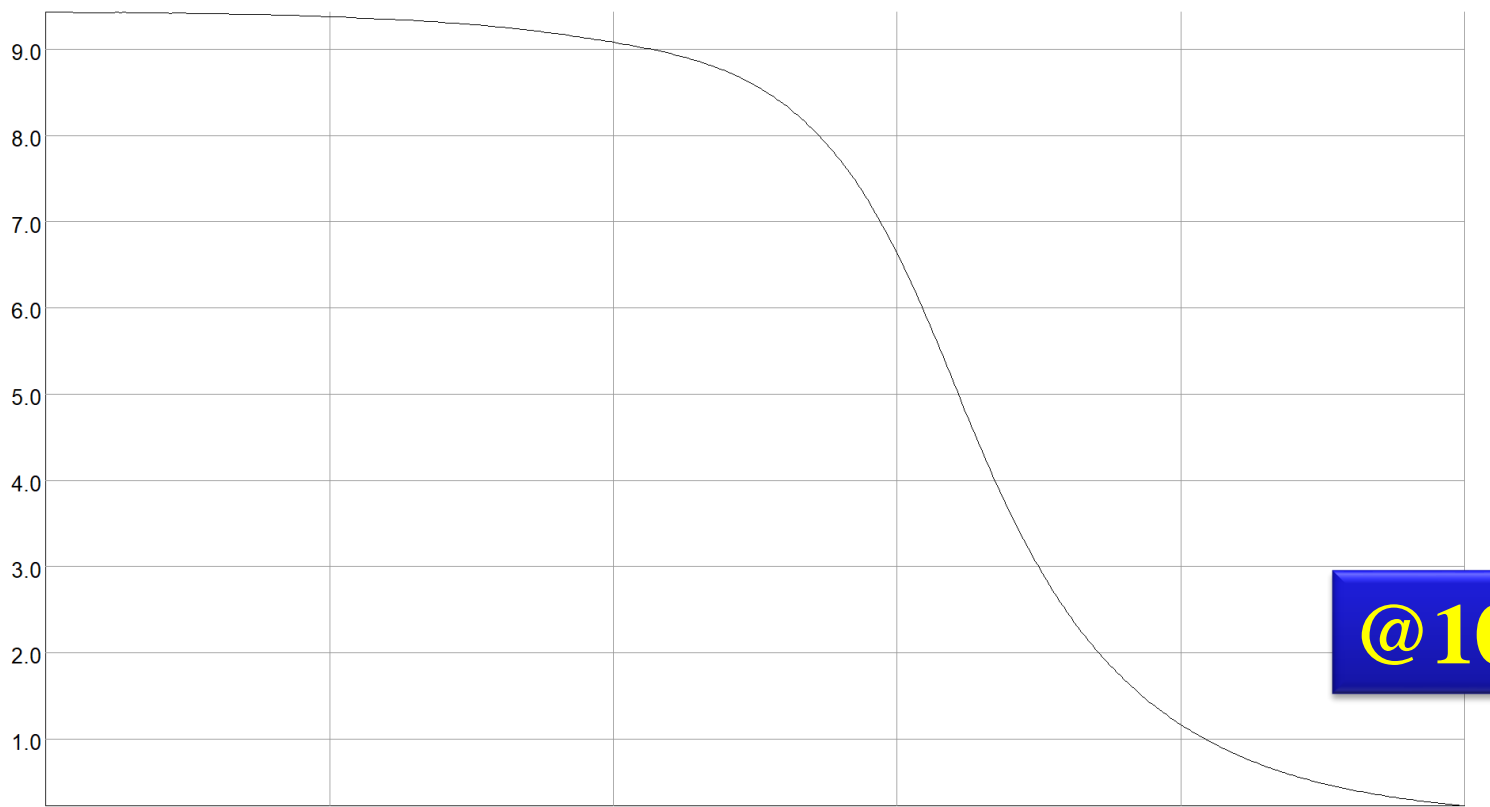

X coord	0.0	0.0	0.0	0.0	0.0	0.0
Y coord	118.0	118.0	118.0	118.0	118.0	118.0
Z coord	0.0	80.0	160.0	240.0	320.0	400.0

Component: B, from buffer: Line, Integral = 2473.79306925243

**@10 kA**

**UNITS**  
 Length mm  
 Magn Flux Density T  
 Magn Field A m<sup>-1</sup>  
 Magn Scalar Pot A  
 Magn Vector Pot Wb m<sup>-1</sup>  
 Elec Flux Density Cm<sup>-1</sup>  
 Elec Field V m<sup>-1</sup>  
 Conductivity S mm<sup>-1</sup>  
 Current Density A mm<sup>-2</sup>  
 Power W  
 Force N  
 Energy J  
 Mass kg

**MODEL DATA**  
 dc017-no-ns-usmdp.op3  
 TOSCA Magnetostatic  
 Nonlinear materials  
 Simulation No. 1 of 1  
 47698232 elements  
 9454251 nodes  
 8 conductors  
 Nodally interpolated fields  
 Activated in global coordinates  
 Reflection in X-Y plane (Z field=0)  
 Reflection in Y-Z plane (X field=0)

**Field Point Local Coordinates**  
 Local = Global

**FIELD EVALUATIONS**  
 Line LINE (node) 401 Cartesian  
 x=0.0 y=118.0 z=0.0 to 400.0

# B along the x-axis at z=0 (upper bore)

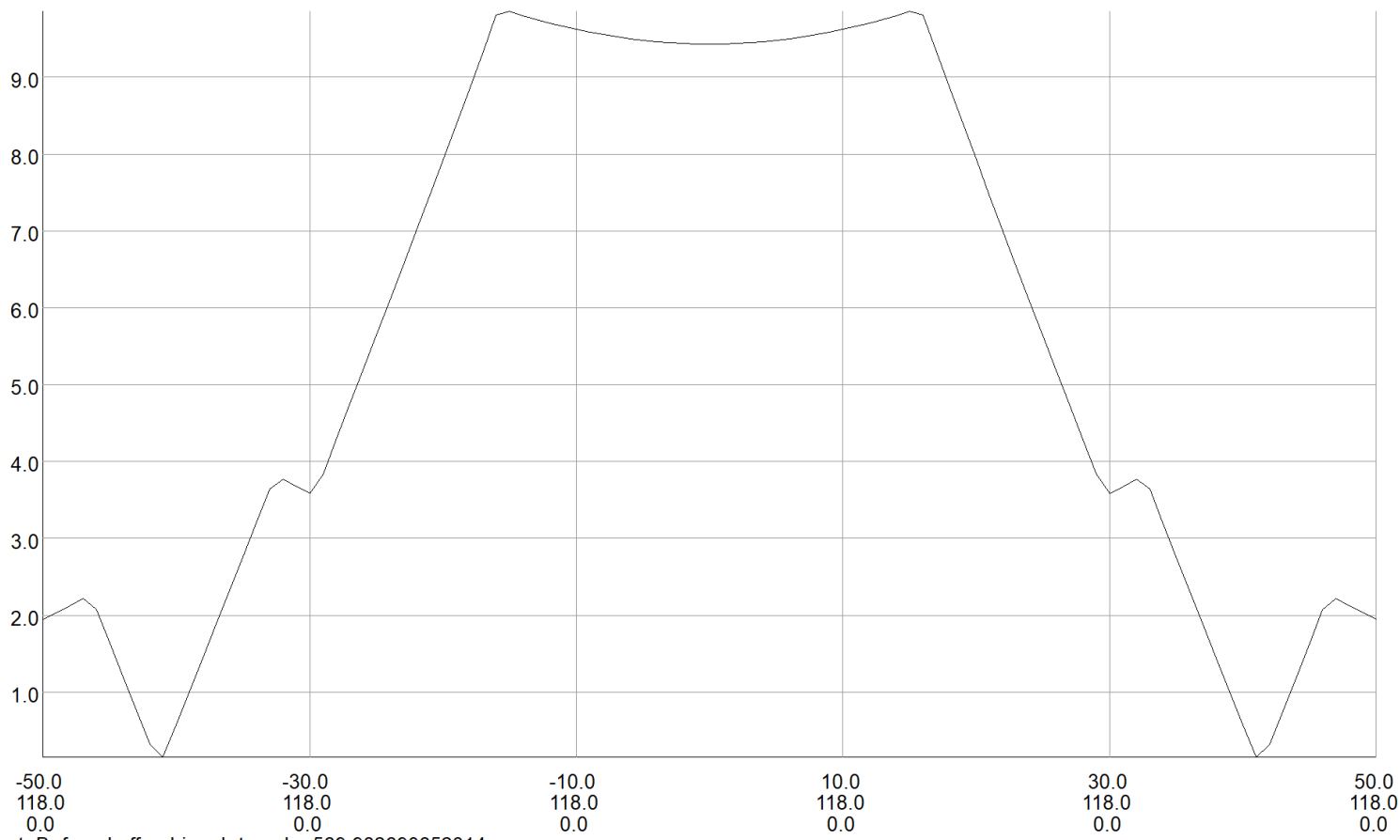

X coord	-50.0	-30.0	-10.0	10.0	30.0	50.0
Y coord	118.0	118.0	118.0	118.0	118.0	118.0
Z coord	0.0	0.0	0.0	0.0	0.0	0.0

Component: B, from buffer: Line, Integral = 569.982690652314

<b>UNITS</b>
Length mm
Magn Flux Density T
Magn Field A m <sup>-1</sup>
Magn Scalar Pot A
Magn Vector Pot Wb m <sup>-1</sup>
Elec Flux Density Cm <sup>-1</sup>
Elec Field V m <sup>-1</sup>
Conductivity S mm <sup>-1</sup>
Current Density A mm <sup>-2</sup>
Power W
Force N
Energy J
Mass kg
<b>MODEL DATA</b>
dc017-no-ris-usmdp.op3
TOSCA Magnetostatic
Nonlinear materials
Simulation No. 1 of 1
47698232 elements
9454251 nodes
8 conductors
Nodally interpolated fields
with B and H by integration
Activated in global coordinates
Reflection in XY plane (z field=0)
Reflection in YZ plane (x field=0)
<b>Field Point Local Coordinates</b>
Local = Global
<b>FIELD EVALUATIONS</b>
Line LINE (nodal) 101 Cartesian
x=-50.0 to 50.0 y=118.0 z=0.0

**@10 kA**

Opera

# Magnitude of the Axial Field ( $B_z$ ) Map in DCC017 in the End Region

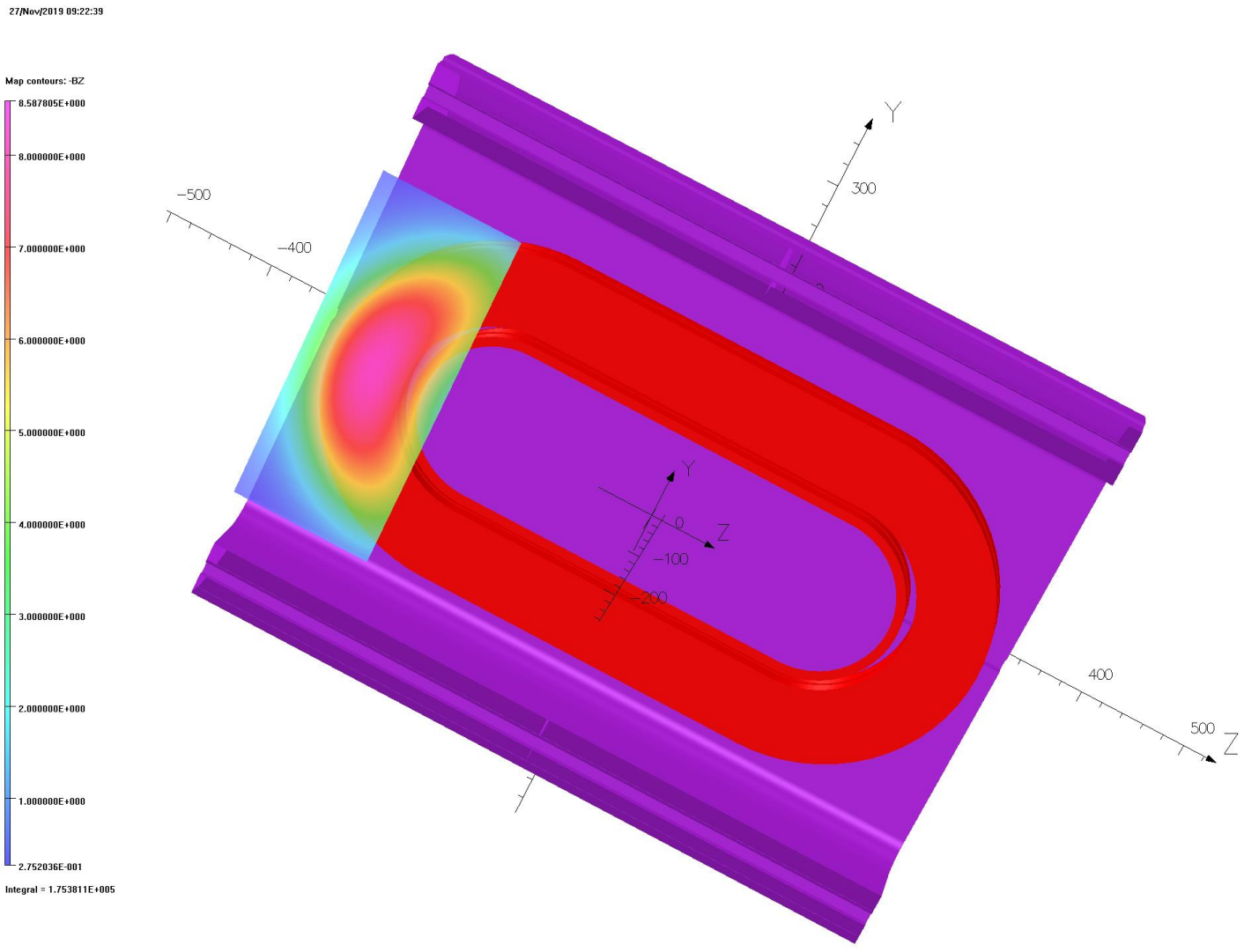

**UNITS**

Length	mm
Magn Flux Density	T
Magn Field	A m <sup>-1</sup>
Magn Scalar Pot	A
Magn Vector Pot	Wb m <sup>-1</sup>
Elec Flux Density	C m <sup>-2</sup>
Elec Field	V m <sup>-1</sup>
Conductivity	S mm <sup>-1</sup>
Current Density	A mm <sup>-2</sup>
Power	W
Force	N
Energy	J
Mass	kg

**MODEL DATA**

dcc017-no-ins-usmb.op3  
 TOSCA Magnetostatic  
 Nonlinear materials  
 Simulation No. 1 of 1  
 47998232 elements  
 9454251 nodes  
 8 conductors  
 Nodally interpolated fields  
 Activated in global coordinates  
 Reflection in XY plane (Z field=0)  
 Reflection in YZ plane (X field=0)

**Field Point Local Coordinates**  
 Local = Global

**FIELD EVALUATIONS**

Cartesian	CARTESIAN (nodal)	20x20	Cartesian
x=0.0	y=-160.0 to 160.0	z=-330.0 to -200.0	

**@10 kA**

Opera

# Magnitude of the Axial Field (Bz) along the z-axis in DCC017 in the End Region

27/Nov/2019 09:24:59

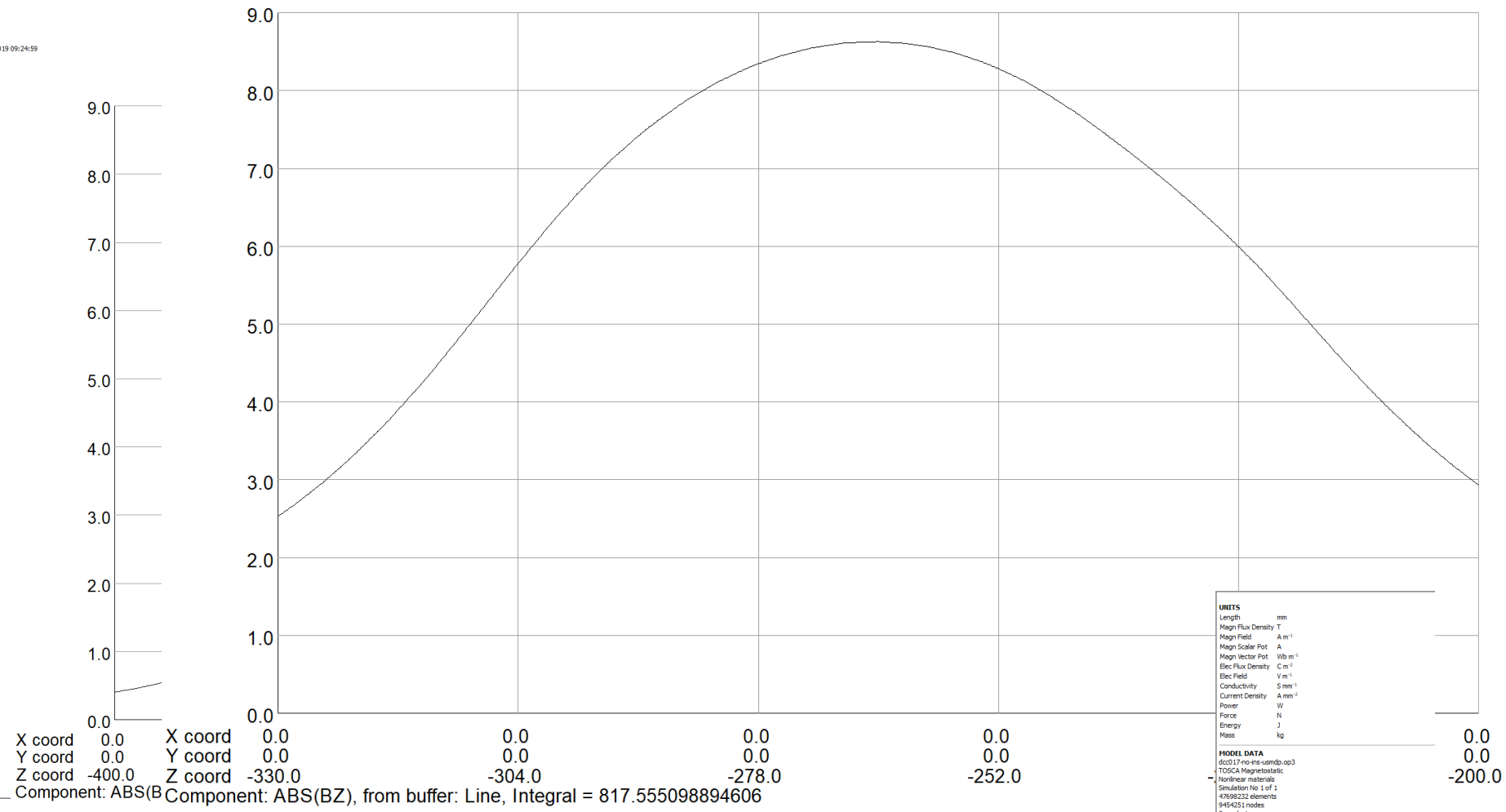

UNITS	
Length	mm
Magn Flux Density T	A m <sup>-1</sup>
Magn Field	A
Magn Vector Pot	Wb m <sup>-1</sup>
Elec Flux Density	C m <sup>-2</sup>
Elec Field	V m <sup>-1</sup>
Conductivity	S mm <sup>-1</sup>
Current Density	A mm <sup>-2</sup>
Power	W
Force	N
Energy	J
Mass	kg

MODEL DATA	
DCC017/m0-m6-ssimids.op3	0.0
TOSCA Magnetostatic	0.0
Nonlinear materials	-200.0
Simulation No. 1 of 1	
47598232 elements	
9454251 nodes	
8 conductors	
Nodally interpolated fields	
Activated in global coordinates	
Reflection in YZ plane (Z field=0)	
Reflection in YZ plane (X field=0)	



# Vertical Field (By) Map in DCC017 in the End Region

27/Nov/2019 09:21:05

Map contours: BY

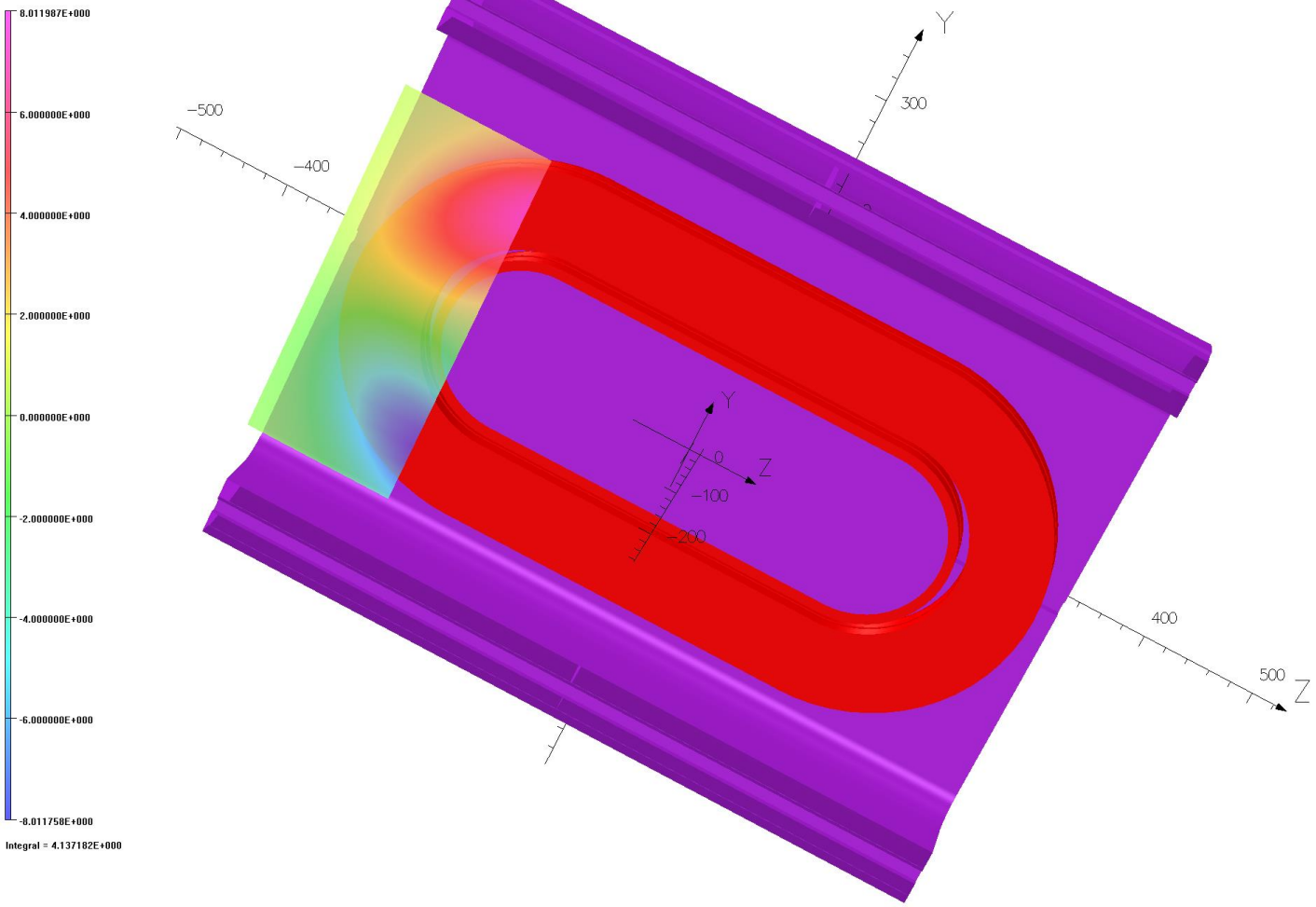

UNITS	
Length	mm
Magn Flux Density	T
Magn Field	A m <sup>-1</sup>
Magn Scaler Pot	A
Magn Vector Pot	Wb m <sup>-1</sup>
Elec Flux Density	C m <sup>-1</sup>
Elec Field	V m <sup>-1</sup>
Conductivity	S mm <sup>-1</sup>
Current Density	A mm <sup>-2</sup>
Power	W
Force	N
Energy	J
Mass	kg

MODEL DATA	
dco17-no-ins-umdb.op3	
TOSCA Magnetostatic	
Nonlinear materials	
Simulation No. 1 of 1	
47696232 elements	
9454251 nodes	
0 conductors	
Nodally interpolated fields	
Activated in global coordinates	
Reflection in XY plane (Z field=0)	
Reflection in YZ plane (X field=0)	

Field Point Local Coordinates	
Local = Global	

FIELD EVALUATIONS		
Cartesian CARTESIAN (nodal) 20x20	Cartesian	
x=0.0	y=-160.0 to 160.0	z=-330.0 to -200.0

**@10 kA**

Opera

# Models of Insert Coil Testing in DCC017



# Insert Coil Test Configuration #1 (common coil insert)

UNITS  
Length: mm  
Magn Flux Density: T  
Magn Field: A m<sup>-1</sup>  
Magn Scalar Pot: A  
Magn Vector Pot: Wb m<sup>-1</sup>

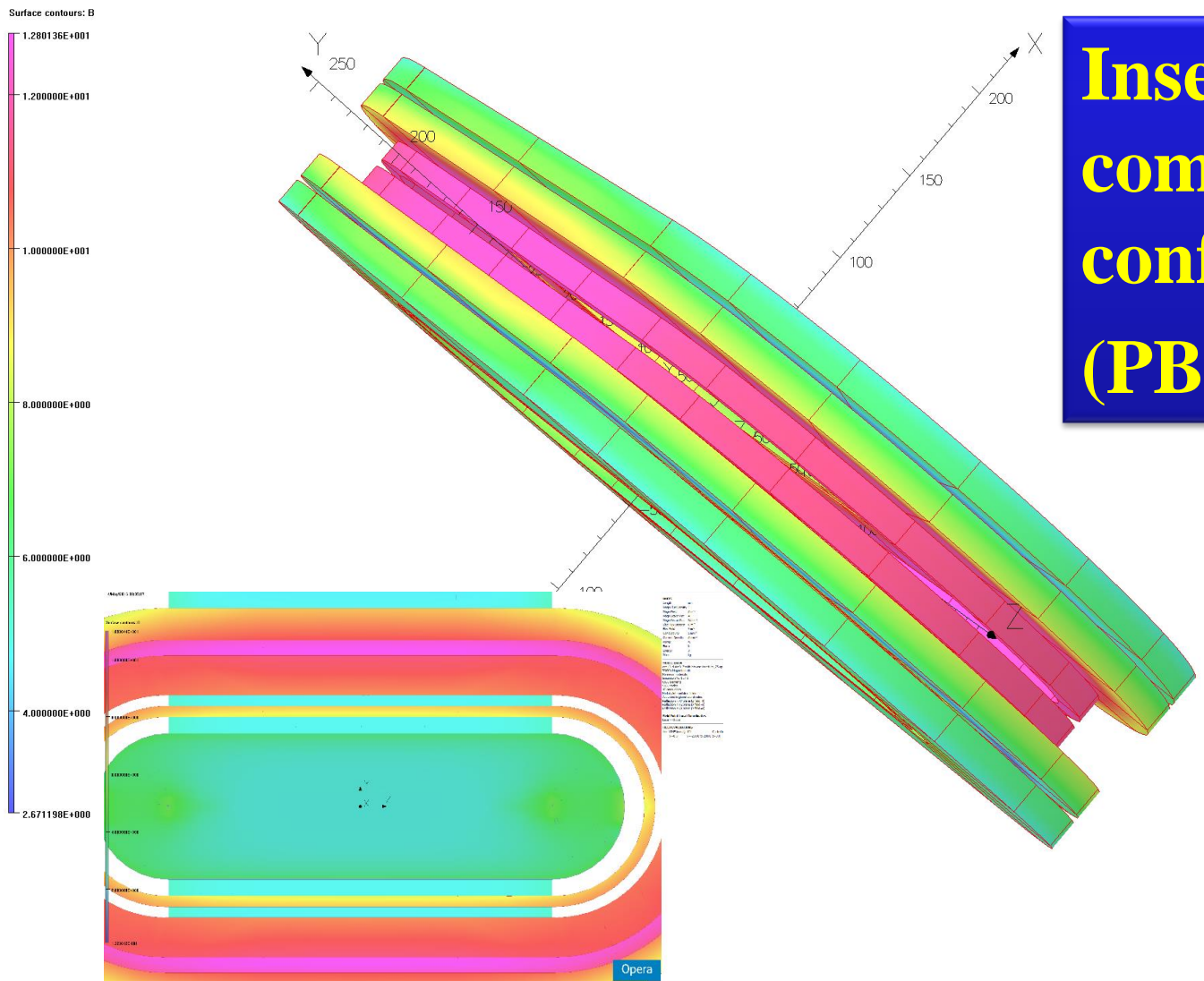

**Insert coils in  
common coil  
configuration  
(PBL/MT25)**

Opera

# Insert Coil Test Configuration #2 (one coil insert in one bore)

1/Nov/2014 16:42:51

Surface contours: BMOD\*.8

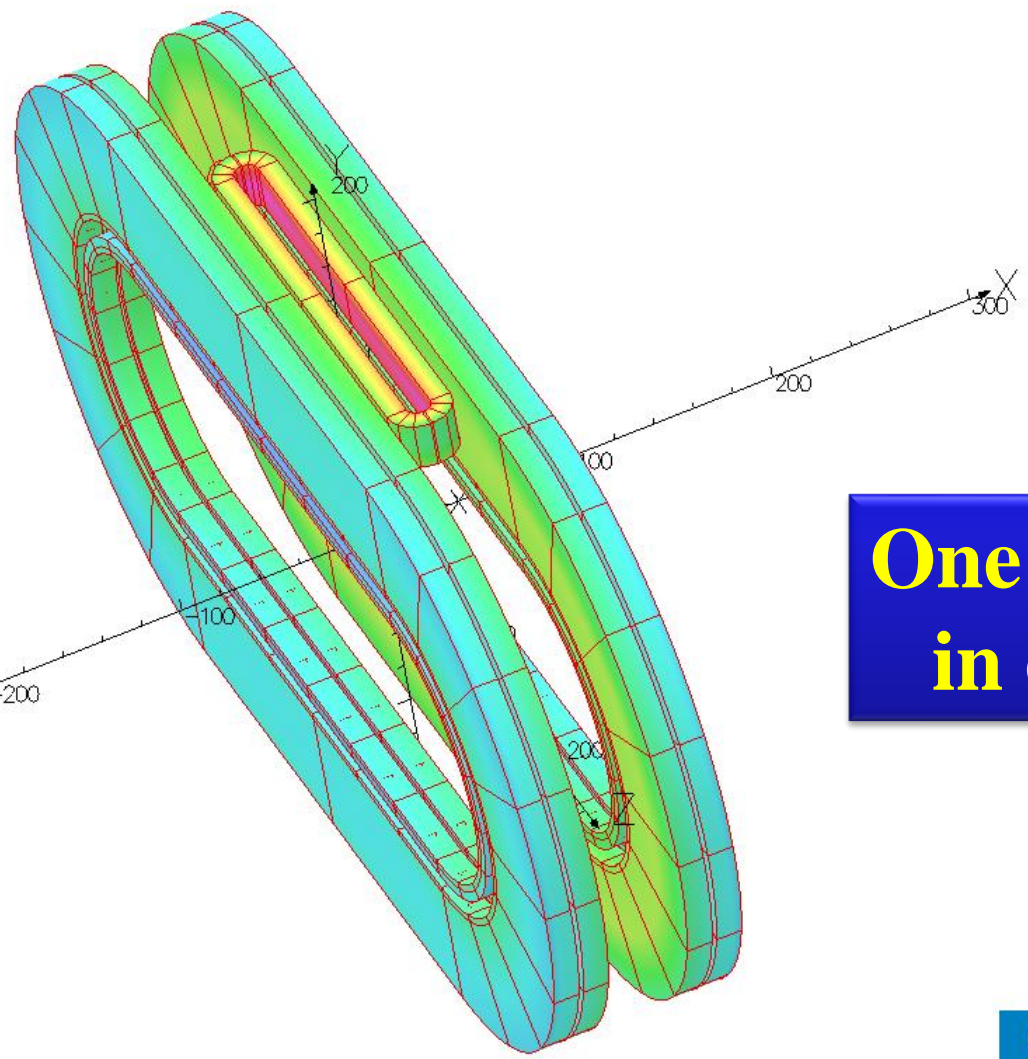
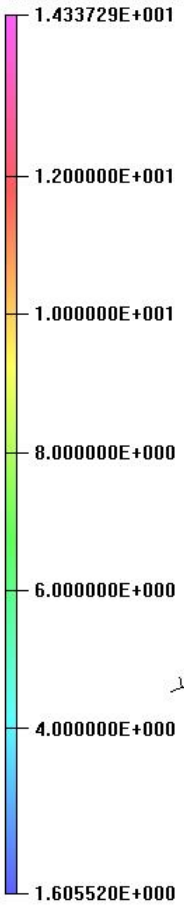

**UNITS**

Length	mm
Magn Flux Density	T
Magn Field	A m <sup>-1</sup>
Magn Scalar Pot	A
Magn Vector Pot	Wb m <sup>-1</sup>
Elec Flux Density	C m <sup>-2</sup>
Elec Field	V m <sup>-1</sup>
Conductivity	S m <sup>-1</sup>
Current Density	A mm <sup>-2</sup>
Power	W
Force	N
Energy	J
Mass	kg

**MODEL DATA**  
17 conductors

**Field Point Local Coordinates**  
Local = Global

**One insert coil  
in one bore**

Opera

# Insert Coils Test Configuration #3 (two coils in two bores, parallel)

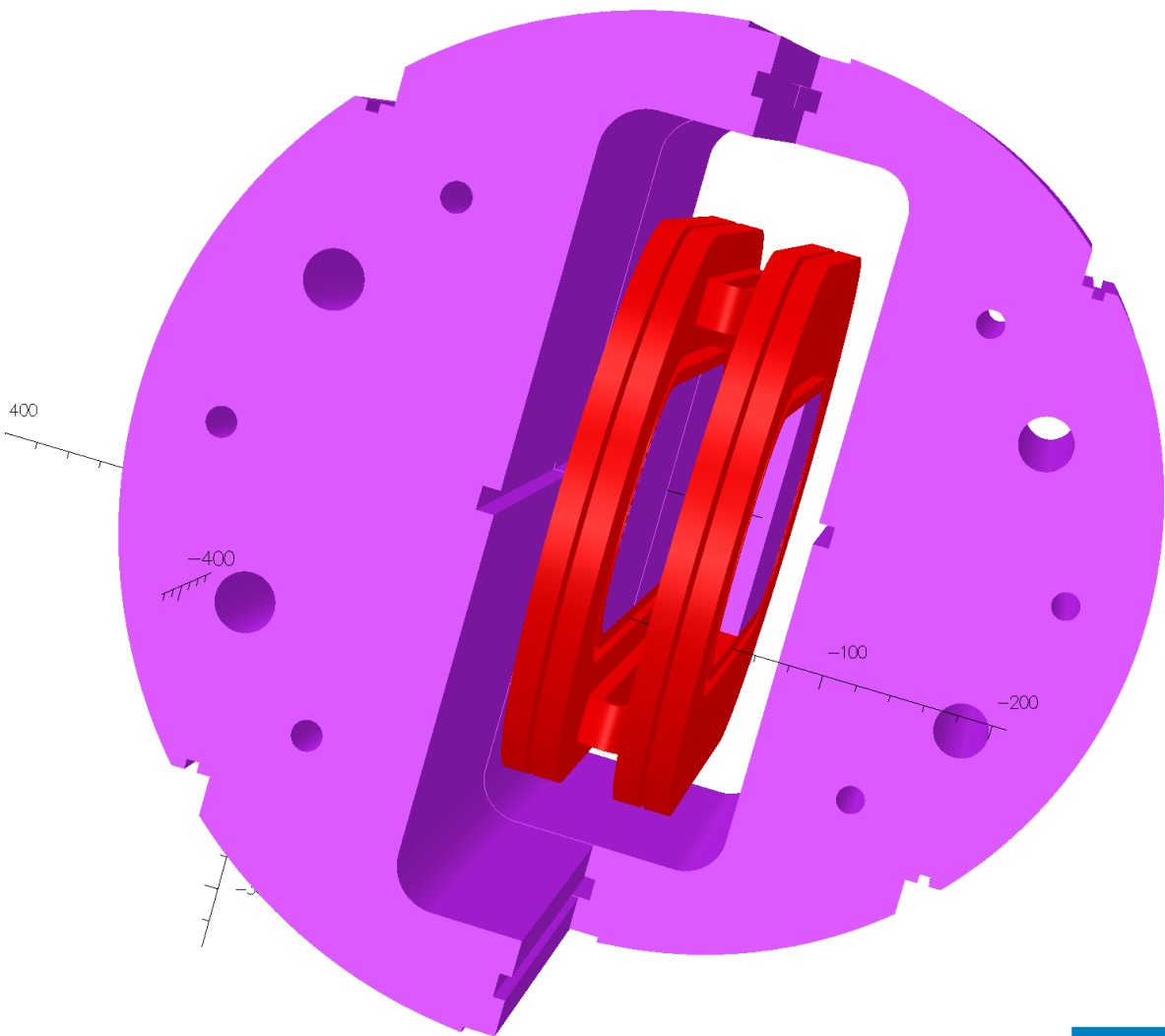

UNITS	
Length	mm
Magn Flux Density	T
Magn Field	A m <sup>-1</sup>
Magn Scalar Pot.	A
Magn Vector Pot.	Wb m <sup>-1</sup>
Elec Flux Density	C m <sup>-2</sup>
Elec Field	V m <sup>-1</sup>
Conductivity	S mm <sup>-1</sup>
Current Density	A mm <sup>-2</sup>
Power	W
Force	N
Energy	J
Mass	kg

MODEL DATA	
dc0117-nl-nomex-hts-ins-both-usmdp.op3	
TOSCA Magnetostatic	
Nonlinear materials	
Simulation hp: 1 of 1	
47698232 elements	
9454251 nodes	
10 conductors	
Nodally interpolated fields	
Activated in global coordinates	
Reflection in XY plane (Z field=0)	
Reflection in YZ plane (X field=0)	

Field Point Local Coordinates	
Local = Global	

  

FIELD EVALUATIONS	
Line LINE (nodal) 101	Cartesian
x=0.0	y=-300.0 to 300.0 z=0.0

**Two insert coils  
in two bores  
(Feb 2020 test)**

Opera

# Insert Coils Test Configuration#4 (two insert coils, parallel & perpendicular)

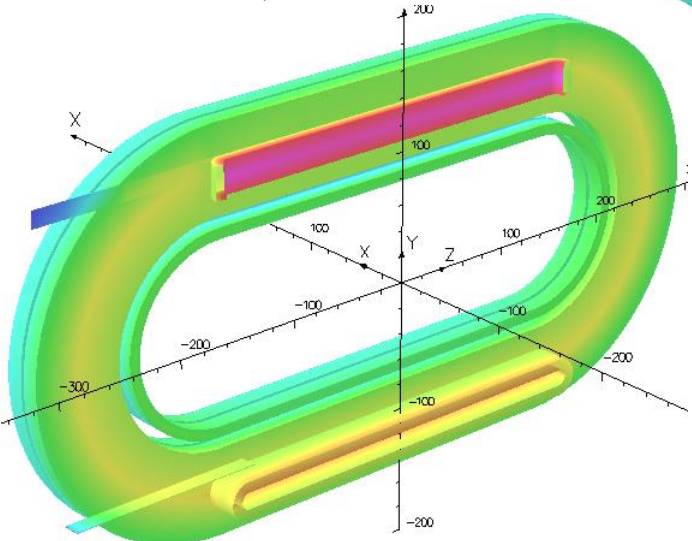
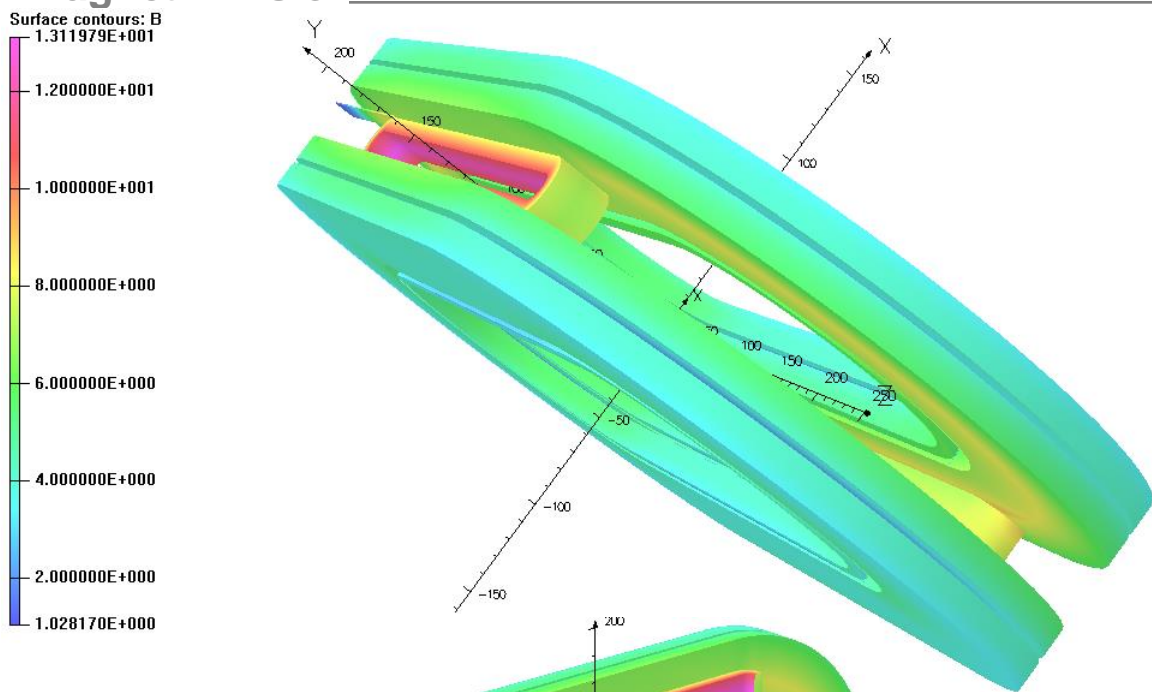

**Cut away view**

**Two HTS insert coils in two bores (apertures) of the common coil dipole**

**(a) Upper bore: Field primarily parallel**

**(b) Lower bore: Field primarily perpendicular**

# Insert Coil Test Configuration #5 (one coil insert, one side in bore)



**Coil partially in field (one side of the coil in one bore)**

D. Martins Araujo :: on behalf of MagDev team :: Paul Scherrer Institute  
BigBOX  
modelling and engineering design progress  
PSI / BNL-MDP Collaboration meeting, February 2022



**Test planned in 2022**

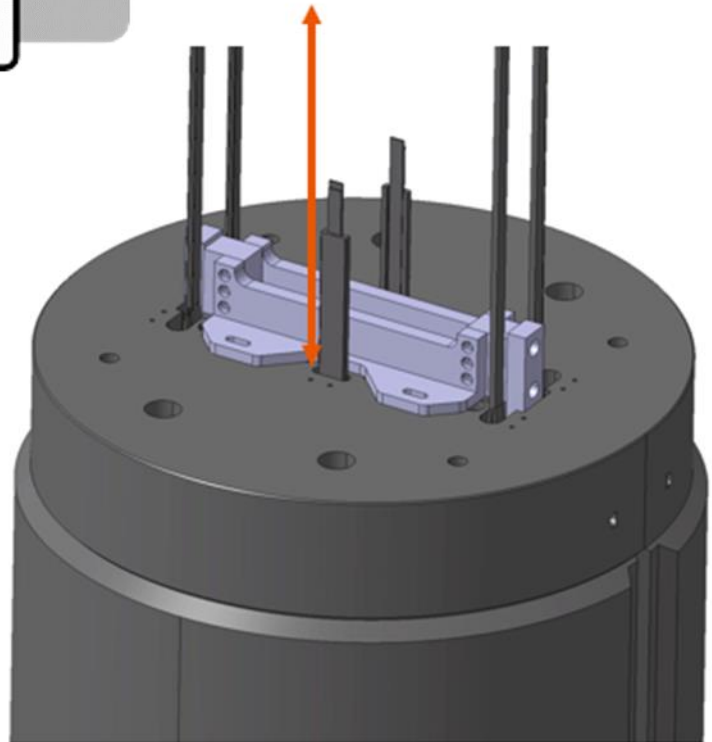
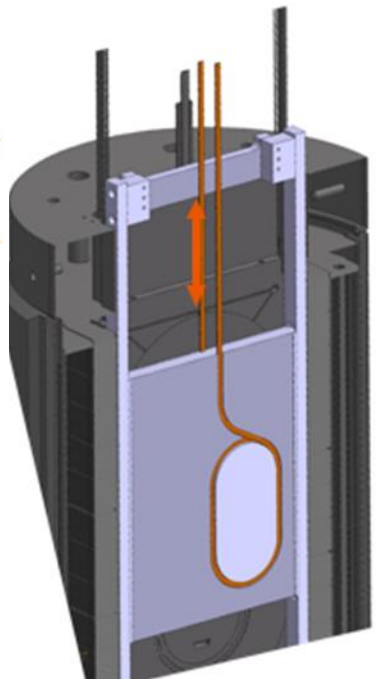
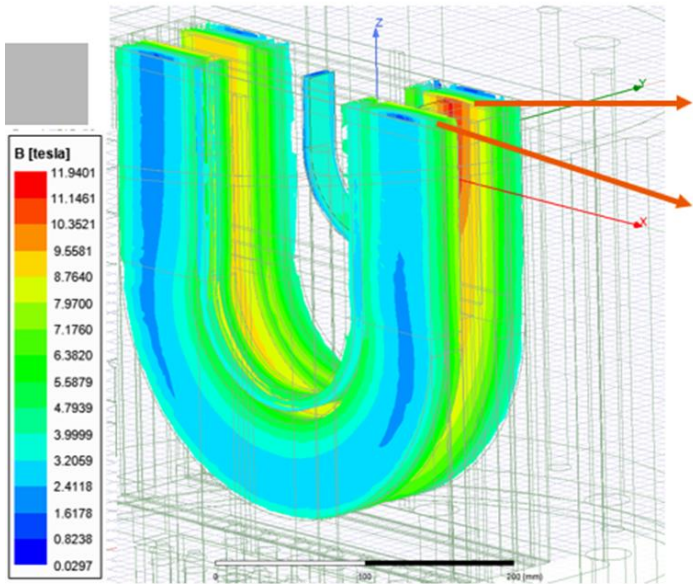

# Models of Cable Testing in DCC017

# Cable Testing Model - View 1

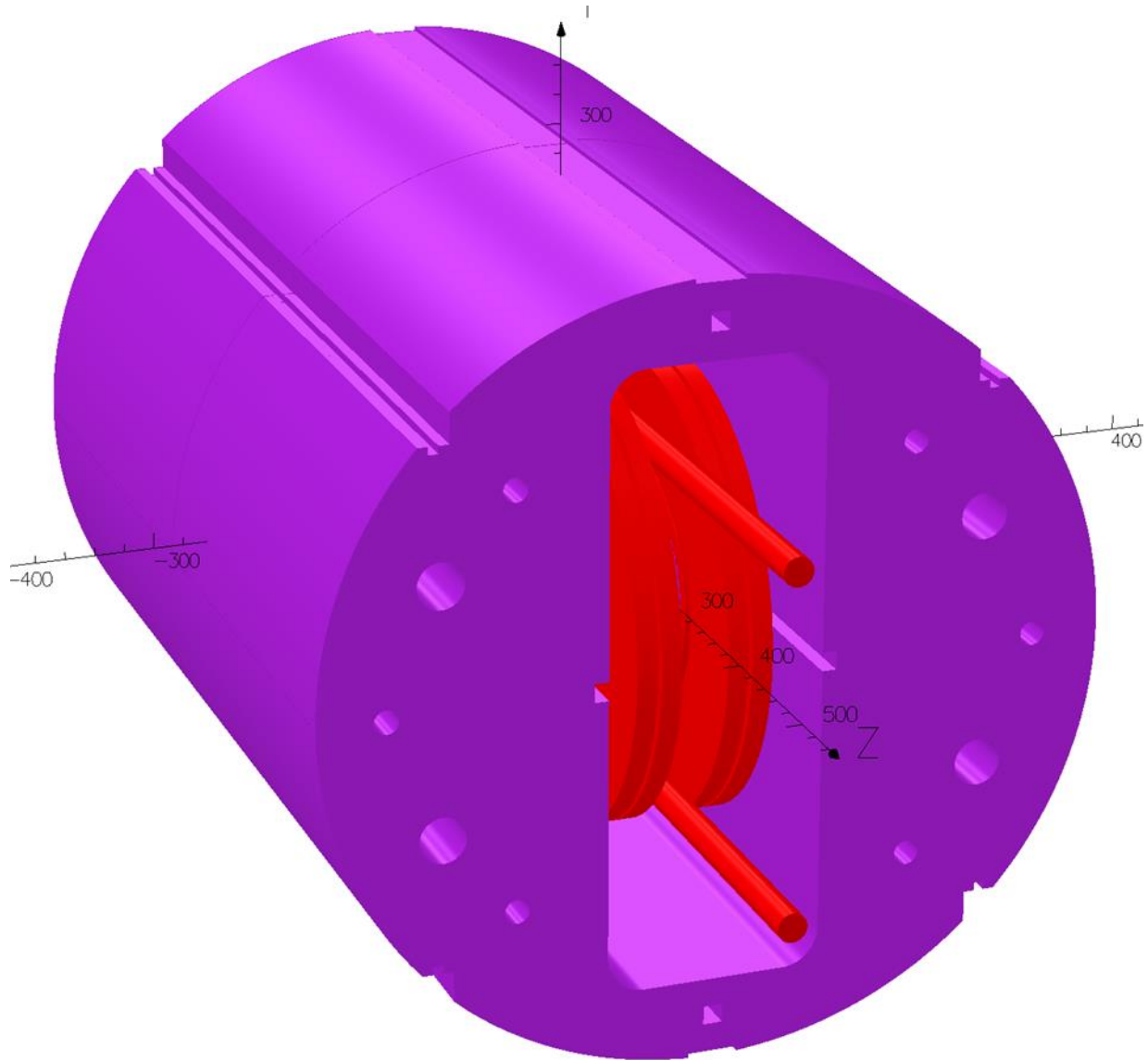

**Single  
turn  
cable test**

# Cable Testing Model - View 2

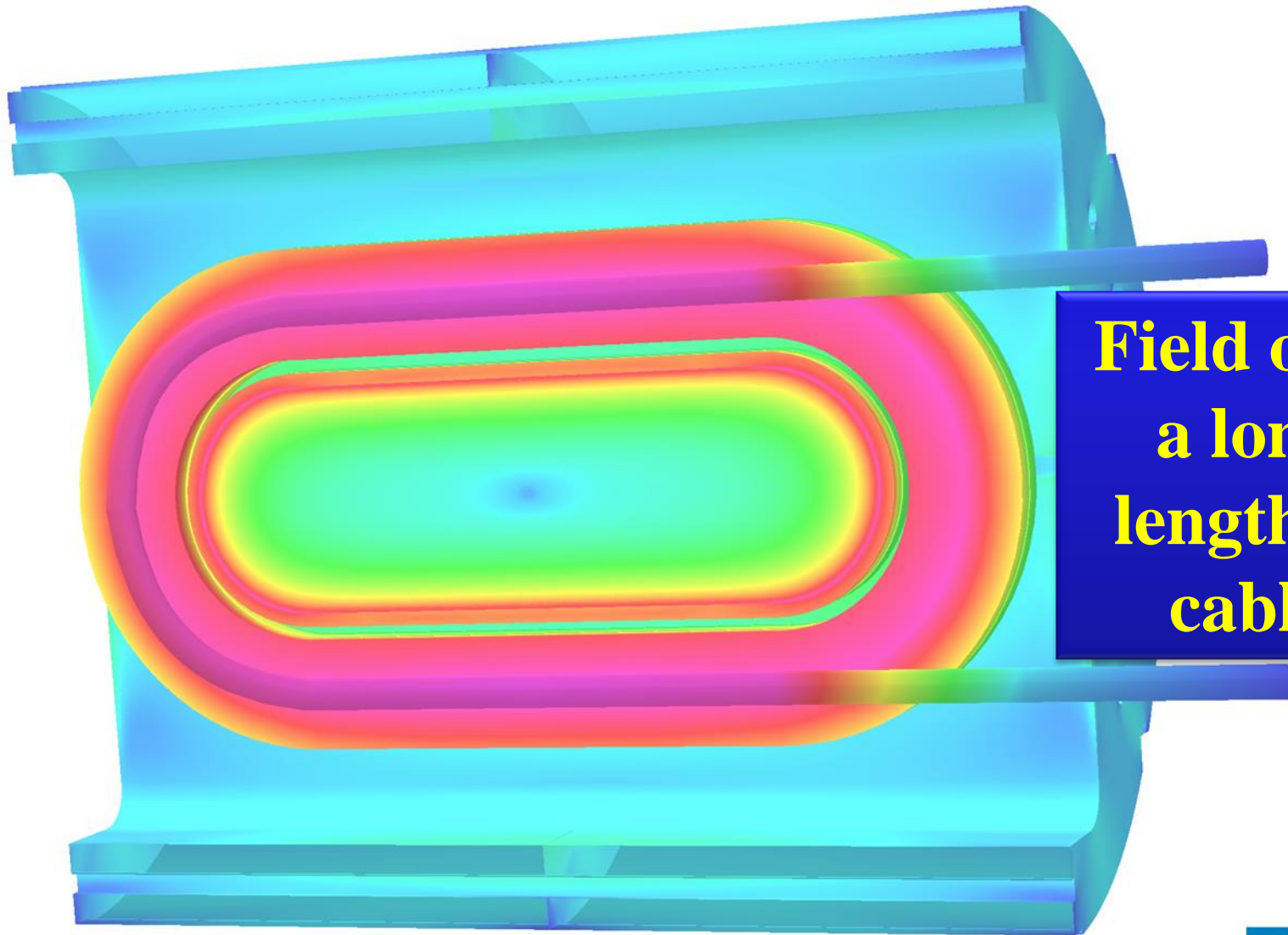
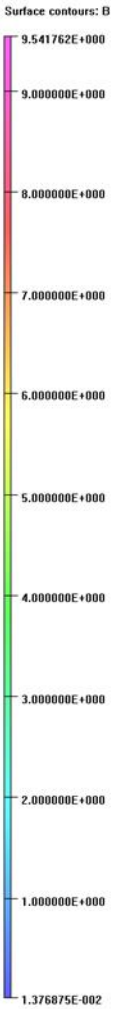

**Field over  
a long  
length of  
cable**



# Cable Testing Model - View 3

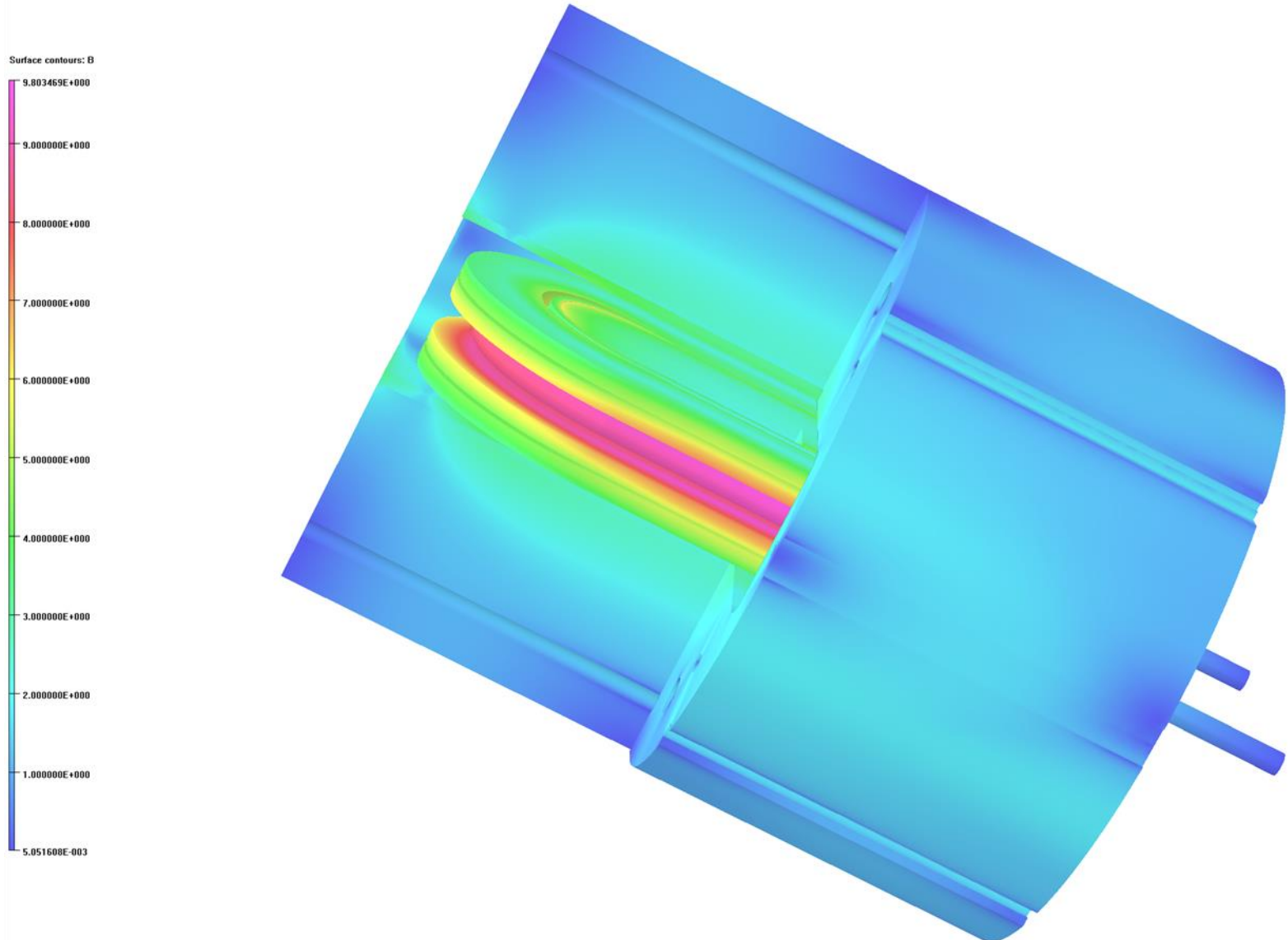

# Cable Testing Model - View 4

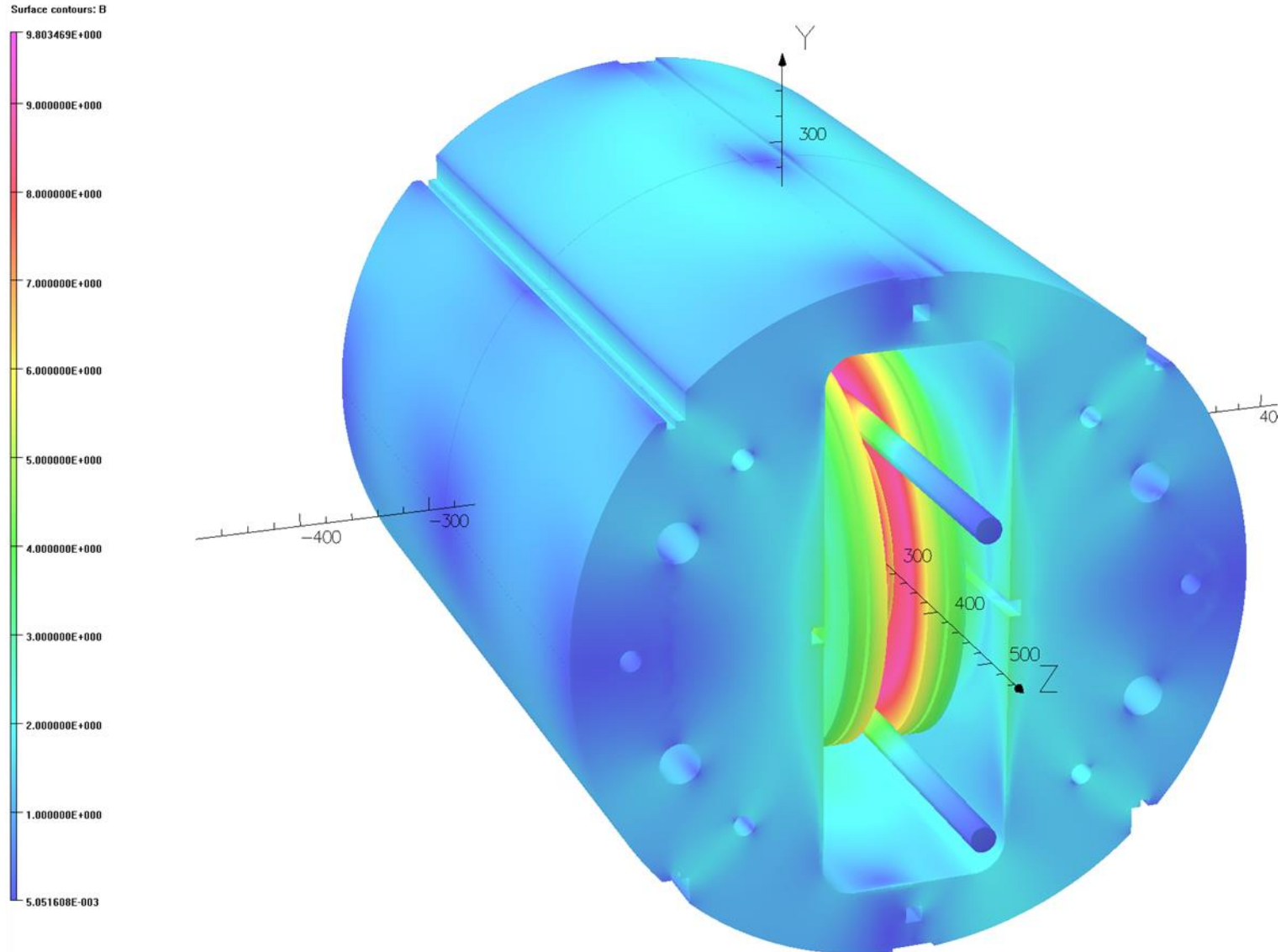

# Multi-turn Cable Test

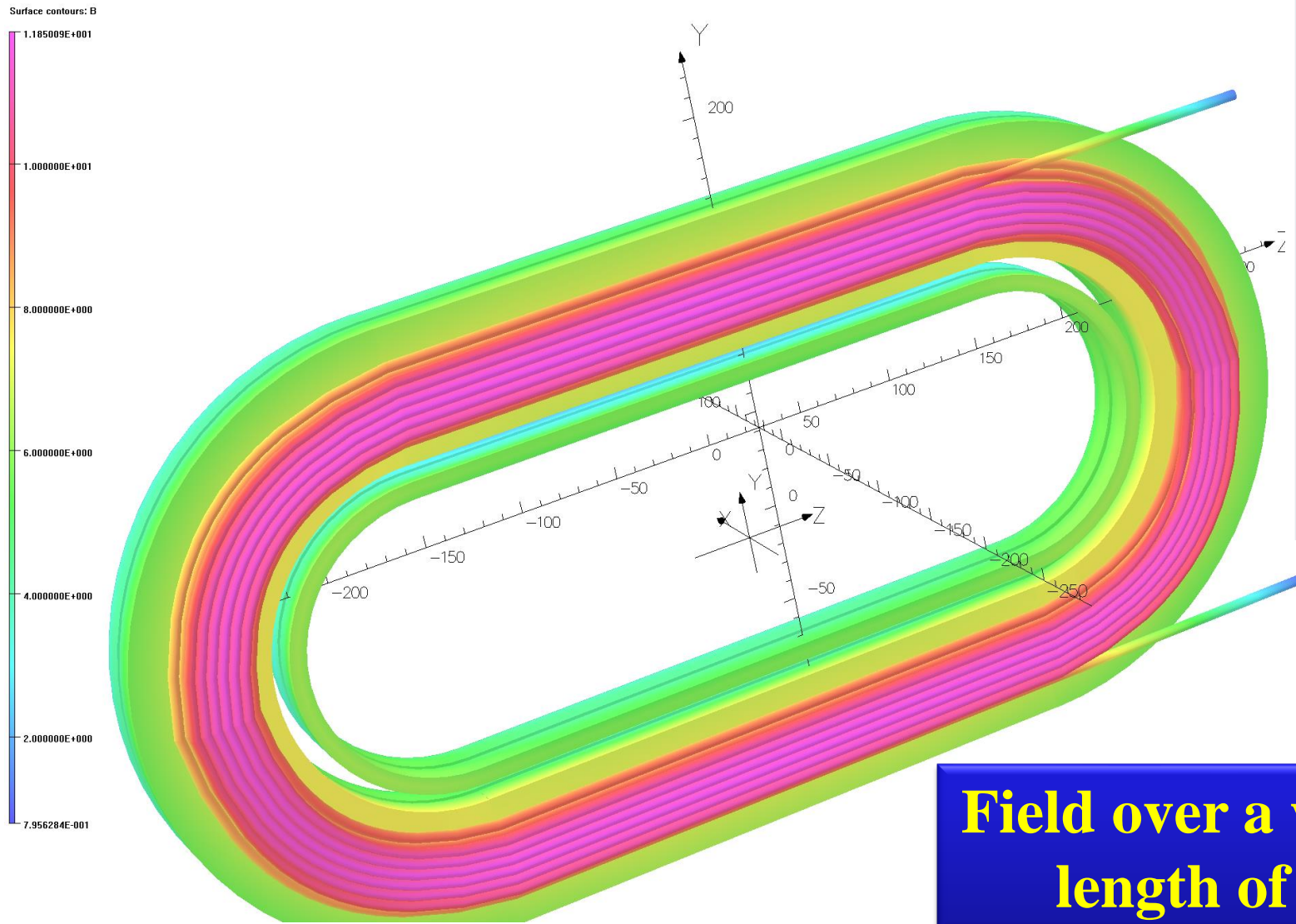

UNITS	
Length	mm
Magn Flux Density	T
Magn Field	A m <sup>-1</sup>
Magn Scalar Pot	A
Magn Vector Pot	Wb m <sup>-1</sup>
Elec Flux Density	C m <sup>-2</sup>
Elec Field	V m <sup>-1</sup>
Conductivity	S m <sup>-1</sup>
Current Density	A mm <sup>-2</sup>
Power	W
Force	N
Energy	J
Mass	kg

---

MODEL DATA	
66 conductors	

---

Field Point Local Coordinate	
Local = Global	

**Field over a very long length of cable**

## Upgrades Under Consideration

### Current setup is for

- Insert coil/cable up to 4.5 kA for any background field up to 10 T
- Insert coil/cable up 10 kA, if in series with common coil

### Future upgrades planned for

- Setup for 20 K testing of cables and insert coils
- Quench detection upgrades, including fiber optics and acoustics
- Insert coil/cable to 7.5 kA for any background field up to 10 T
- Insert coil/cable up to 15 kA, if in series with common coil with added shunt allowing variation in current in insert coil/cable
- Configuring existing power supplies at BNL for 30 kA insert coil or cable testing with upgrade to top-hat
- Transformer inside cryostat allowing up to 100 kA for cable test with any background up to 10 T