



U.S. MAGNET
DEVELOPMENT
PROGRAM

High Temperature HTS Magnet Program at BNL

Ramesh Gupta

Two components of the BNL HTS magnet program:

1. High field HTS and high field HTS/LTS hybrid magnet program (presented Wednesday)
2. Field harmonics measurements and high temperature operation (TODAY)

- Cost-effective, as it is mostly based on the existing hardware
- Collaboration welcome for comparing models Vs. measurements, and also for shaping the program, goals and MDP milestones

Why to start paying attention to field harmonics now?

- Situation in going from “LTS magnets” to “HTS magnets” may be similar to what it was in going from “room temperature magnets” to “superconducting magnets” about 50 years ago.
- Machine physicists might have to find ways to deal with an order of magnitude increase in the low field harmonics. But we must define the issue (magnitude of error harmonics) based on the measurements and validated models to predict them.
- Even Bi2212 cable magnets will have higher persistent current induced harmonics, just as the Nb₃Sn had higher than NbTi (even more if Bi2212 strands get sintered during reaction).
- In ReBCO, tape alignment or striation will reduce the harmonic errors at low fields. However, we need validated models to establish communication with machine physicists.
- Similarly, CORC[®], Twisted tape, VIPER cables, will reduce low-field harmonics as the mechanism which reduces heating in ramping magnets, also reduces the field harmonics.

We should start measuring harmonics in HTS magnets now to validate models to better guide the cable, magnet and the overall machine design approaches.

Magnets with Bore to Measure Field Harmonics

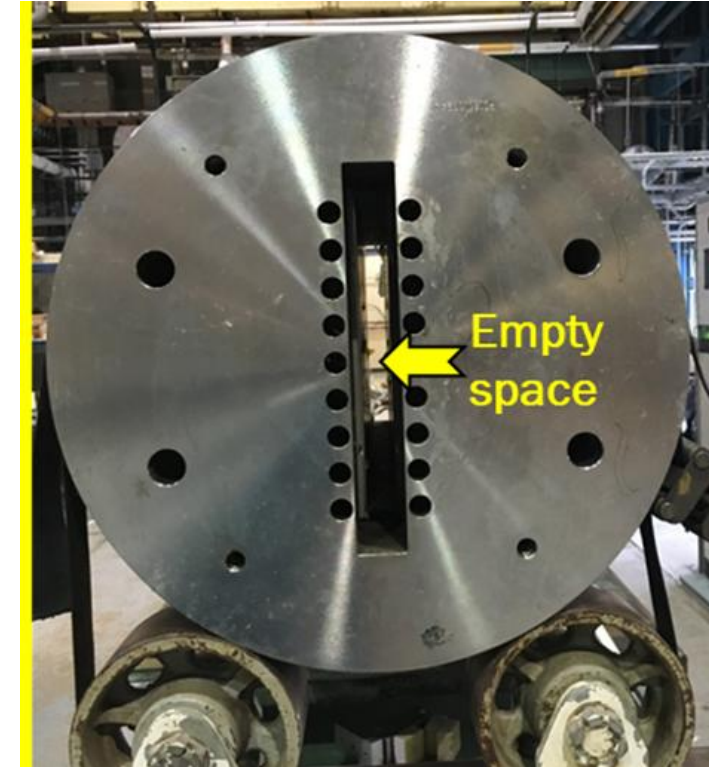
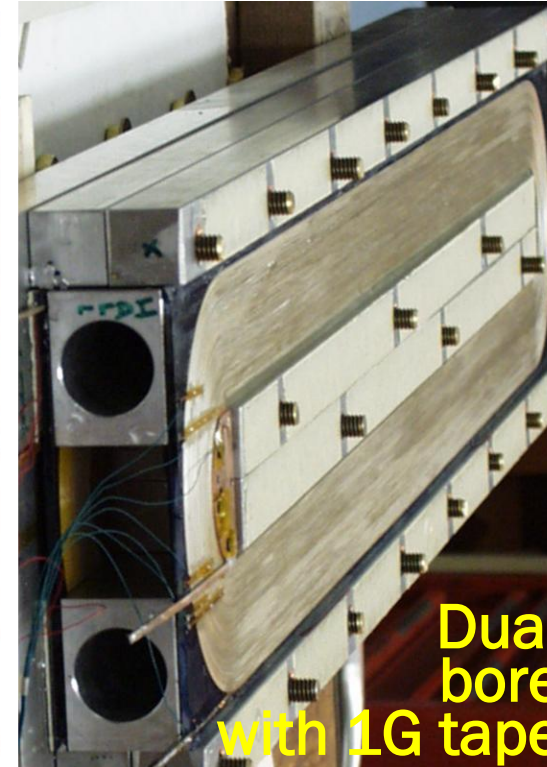
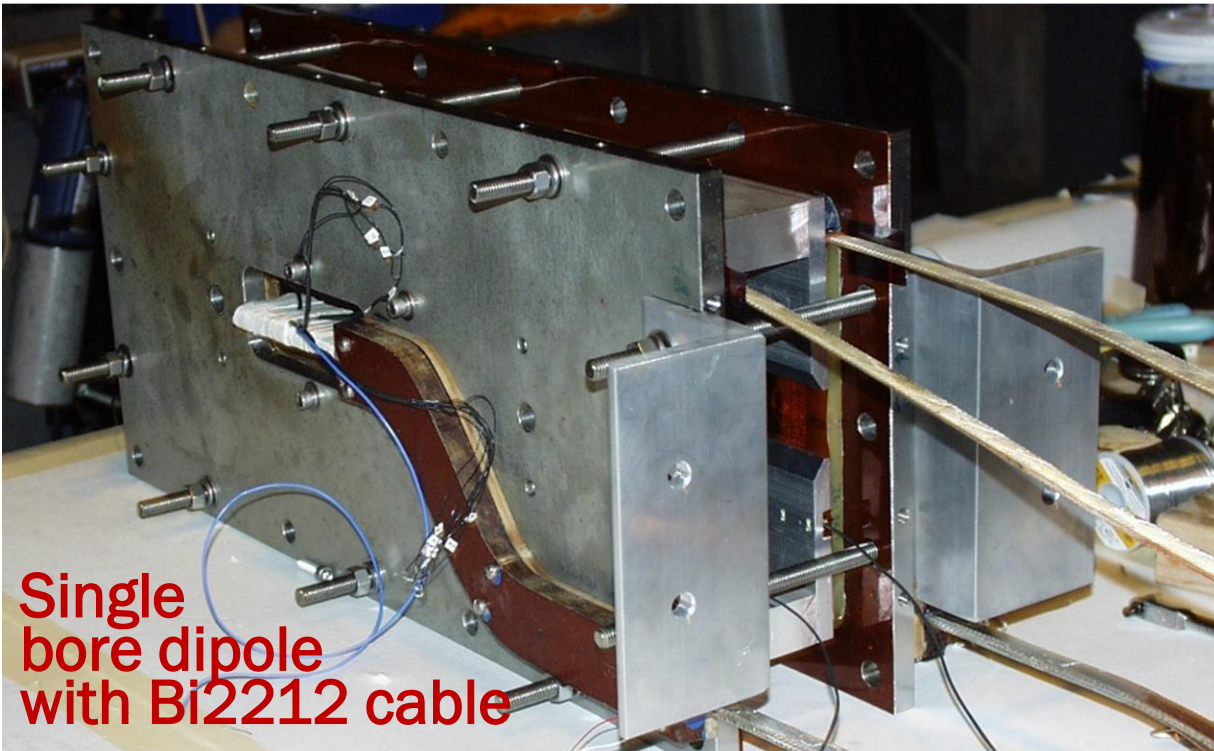

Initial designs of Bi2212 cable dipole (left) and 1G HTS tape dipole (middle) had bores to measure harmonics. Nb₃Sn common coil dipole (right) to provide background field on 2G HTS coil(s) had small space only to put Hall probe to measure magnetization, not field harmonics.



Harmonic Measurements in Bi2212 Cable Magnet at 77 K

R&W Bi2212 Coil



Magnet DCC006: 2nd HTS Dipole (Magnet No. 6 in the common coil cable magnet series)

- Measured harmonics with 1 m long rotating coil
- Small difference between up & down ramps means low harmonics from persistent currents @77K.
- Expect more at 4K when away from critical surface

BROOKHAVEN NATIONAL LABORATORY Superconducting Magnet Division

A versatile structure to test single or double coils in various configurations

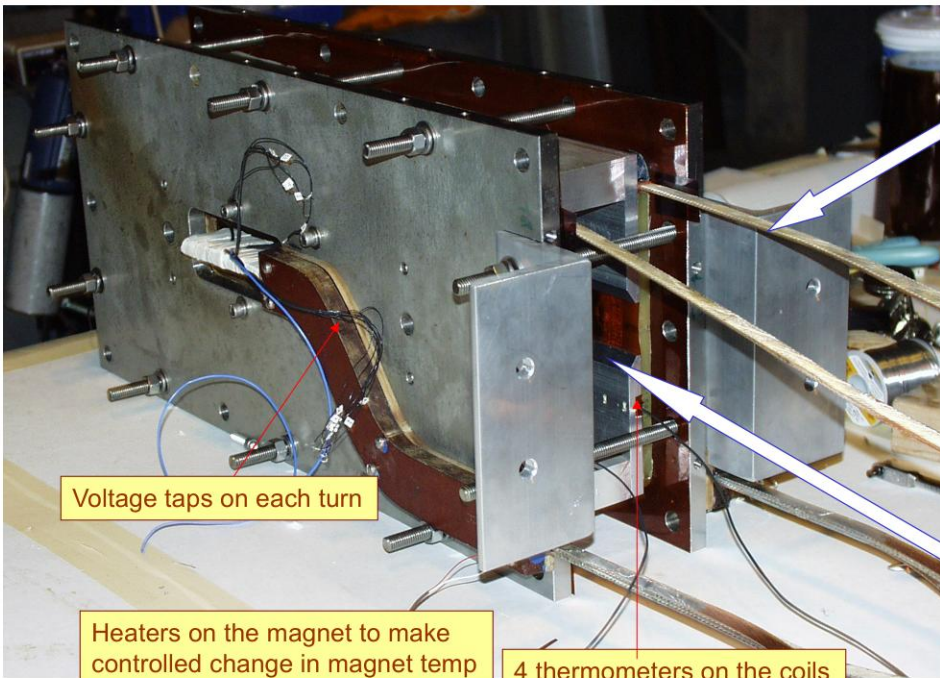

HTS Cable Leads to make high temp measurements

74 mm aperture to measure field quality

Voltage taps on each turn

Heaters on the magnet to make controlled change in magnet temp

4 thermometers on the coils

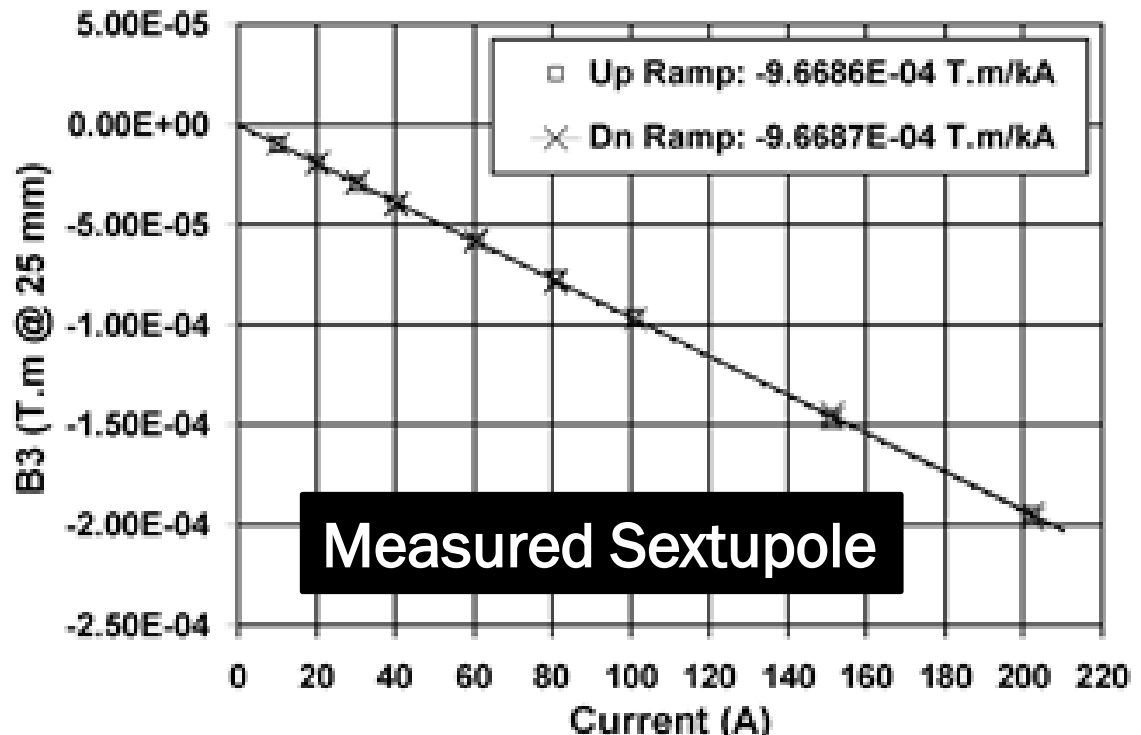

Measured Sextupole





- FRIB Quad with yoke has been retested. All 8 HTS coils are good and we are good to go.
- However, yoke suppress harmonics due to persistent current that we want to quantify.
- 1st step: remove yoke and measure harmonics.
- We already have a dewar for 77 K test.

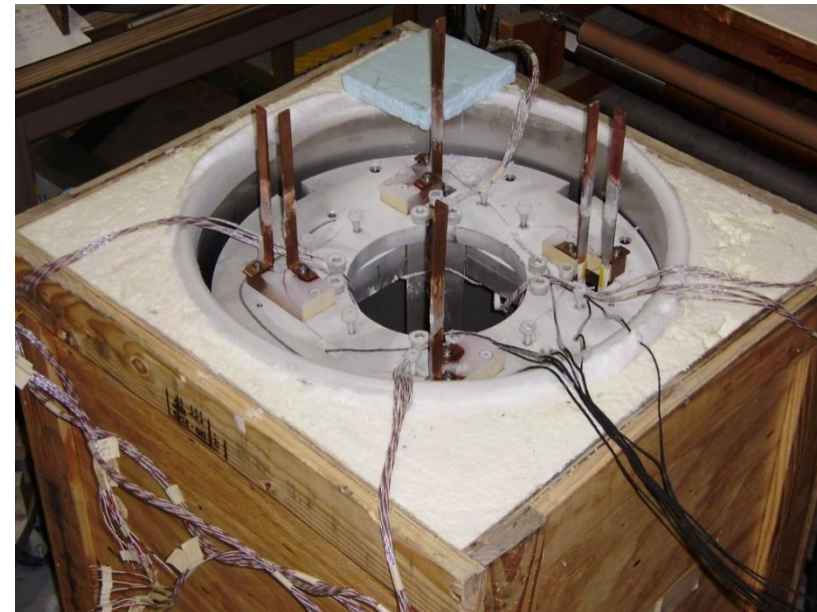

Rotating coil
for harmonic
measurements
to be inserted
vertically



Initial quad configuration with all HTS coils powered

Single aperture dipole (field parallel to the wide face of the HTS tape) or common coil (field perpendicular) configurations of coils made with ASC or SuperPower tape by selectively powering them and flipping polarity.

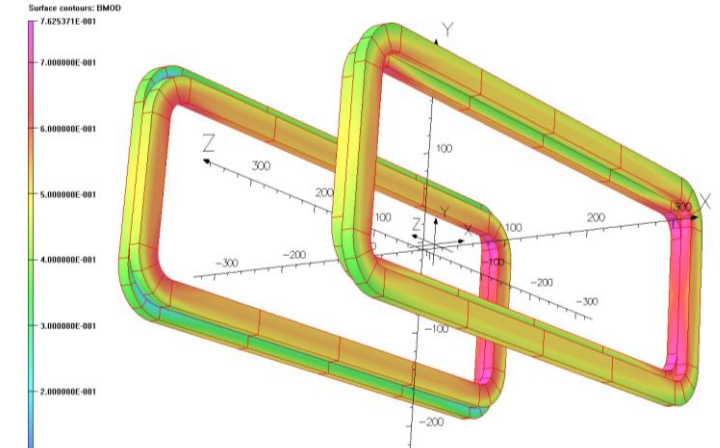
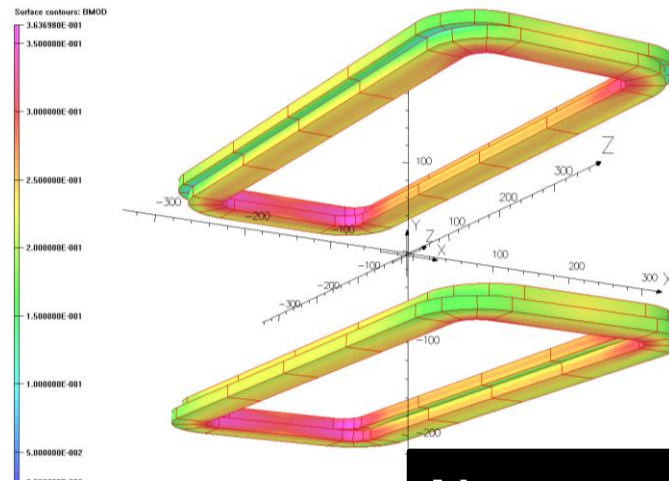
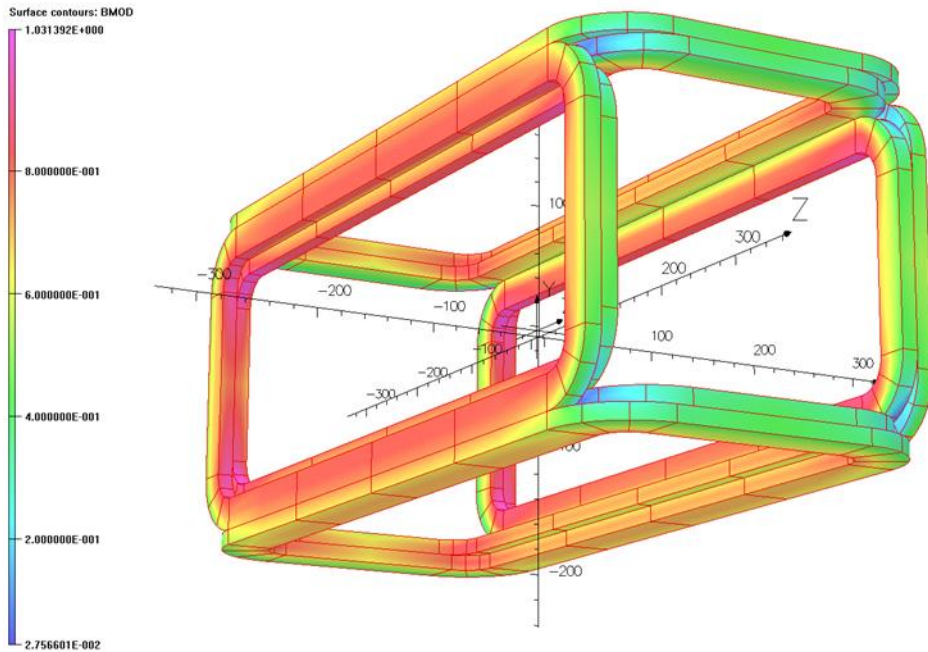

Next step: change the relative separation

These tests should generate healthy amount of experimental data from large HTS coils to help quantify the harmonic errors and to check computer models



- There is a large interest in accelerator and fusion community in operating high field HTS magnets at temperature significantly higher than 4 K (~20 K or so).
- This significantly saves on the operating costs and cryogenic requirements.
- We should evaluate various operating scenarios and evaluate the magnet performance at higher temperatures, beside developing operating experience.
- In fact, it may be beneficial to adapt to high temperature testing during the R&D program for reducing the liquid Helium supply and/or operating costs.
- BNL has significant experience in testing HTS coils and magnets at high temperatures. However, with a limited control on the temperature dialing.
- **BNL plan is to develop a more sophisticated and dialable program control to adjust and hold temperature (it is to be integrated and tested in a few months).**



Testing of HTS Coils as a Function of Temperature

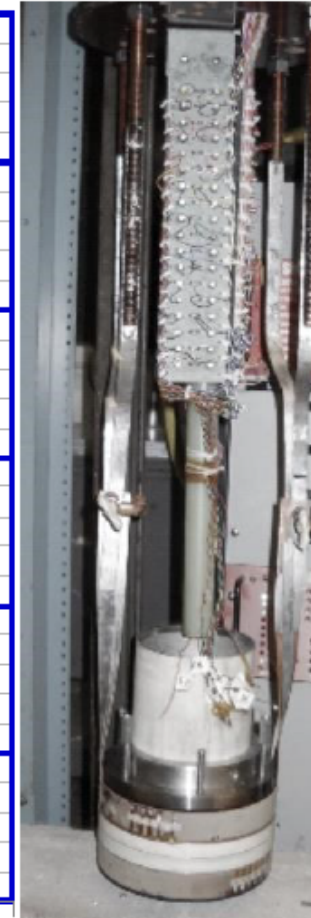
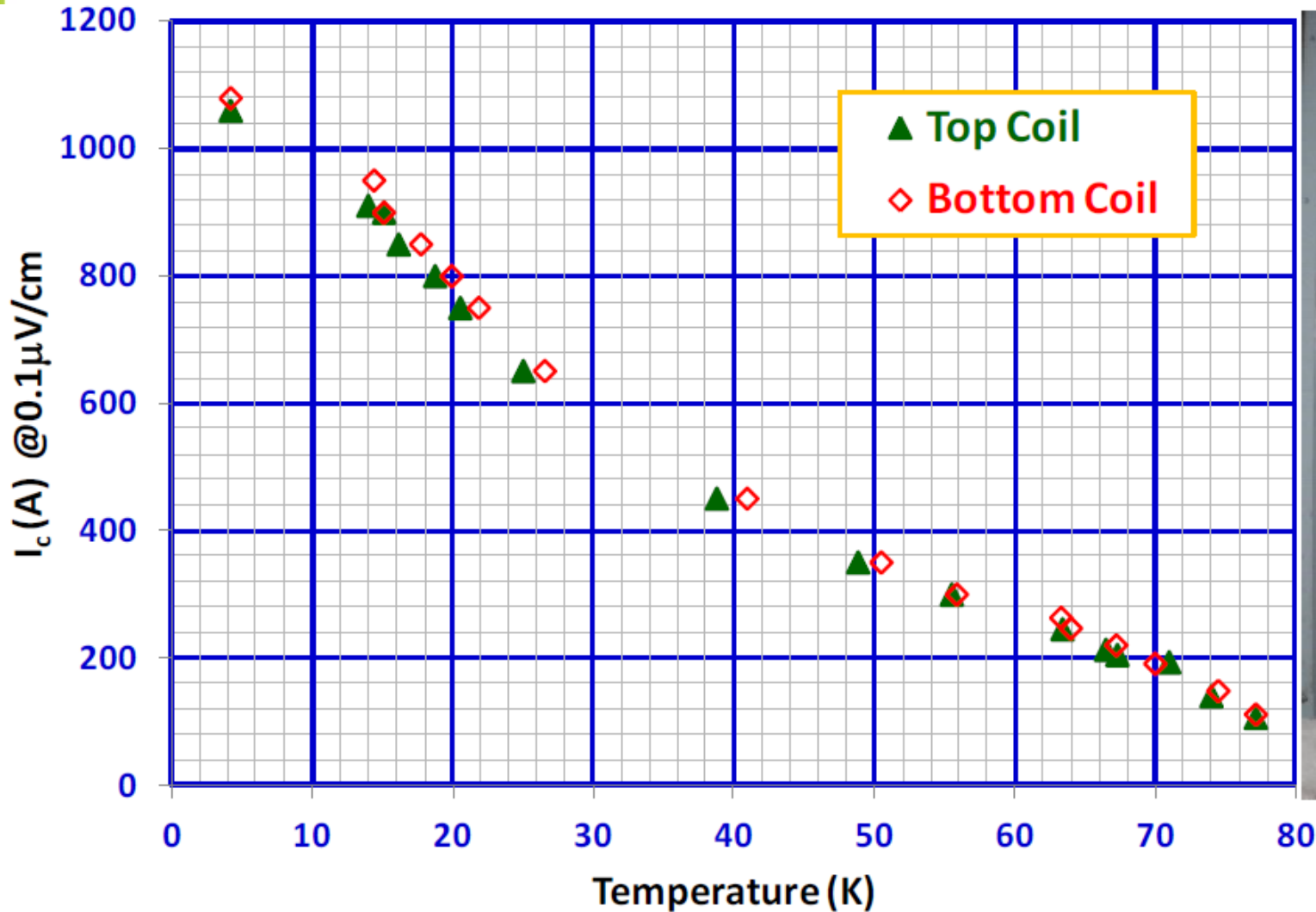

Ramp rate
up to 10 A/s

Testing at different temperature by adjusting Helium flow rate manually or by letting it warm up slowly.

Future: Develop a program to adjust He flow to adjust temperature (Piyush)



HTS SMES Test at 27K

Inner Coil
28 pancakes
(id=102mm, od=196mm)

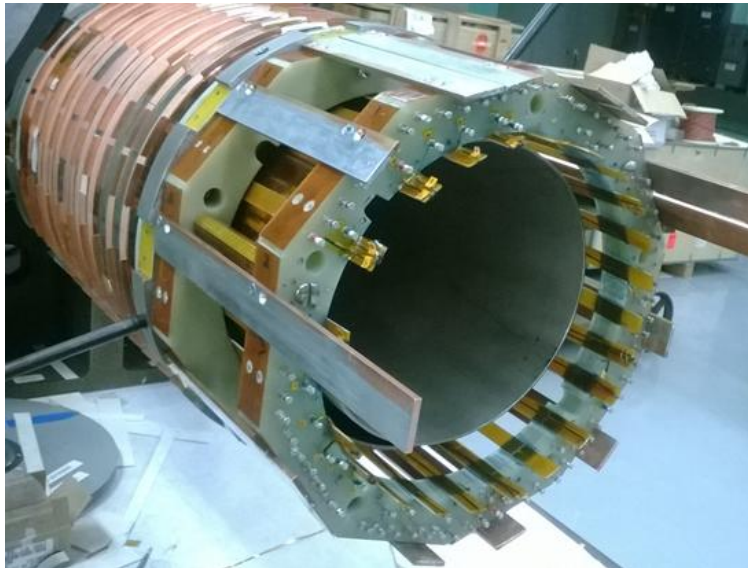
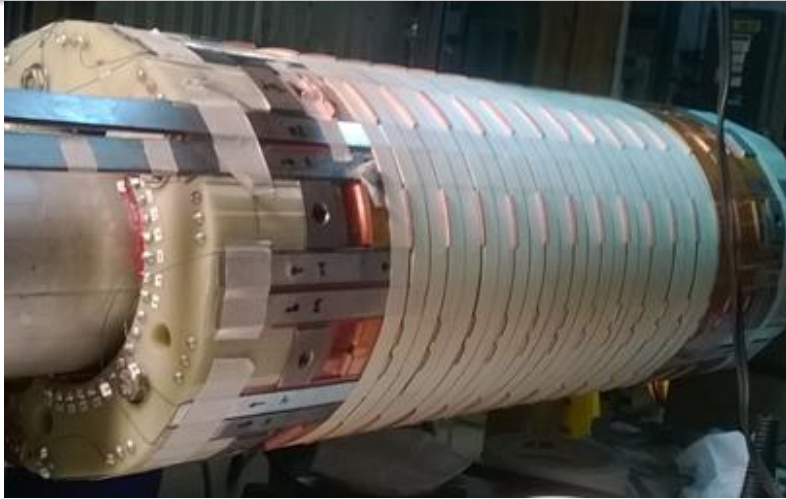

Outer Coil
18 pancakes
(id=223mm, od=303mm)

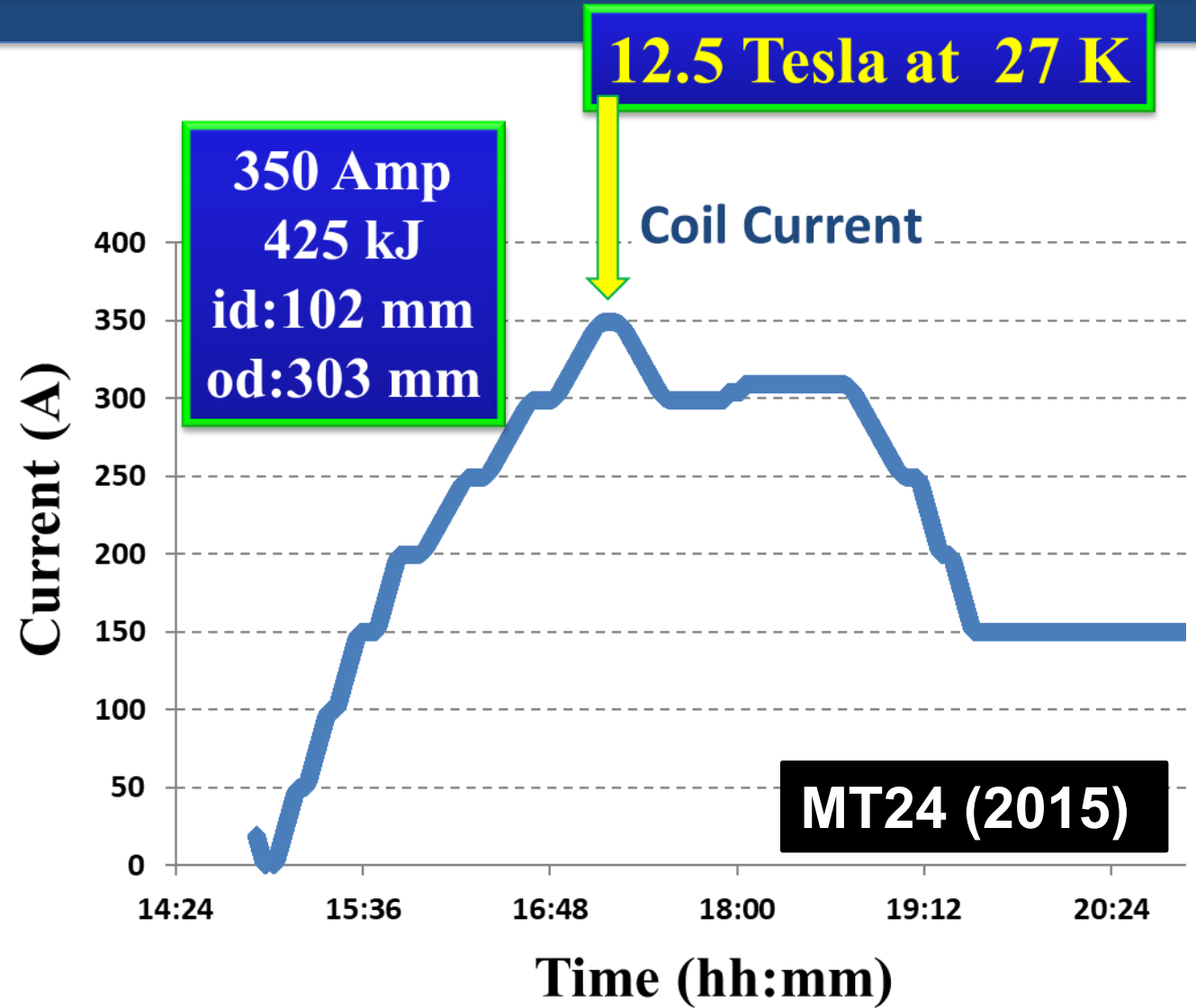

Testing of RIA/FRIB Large 1G HTS Coils

(temperature controlled by adjusting Helium flow)

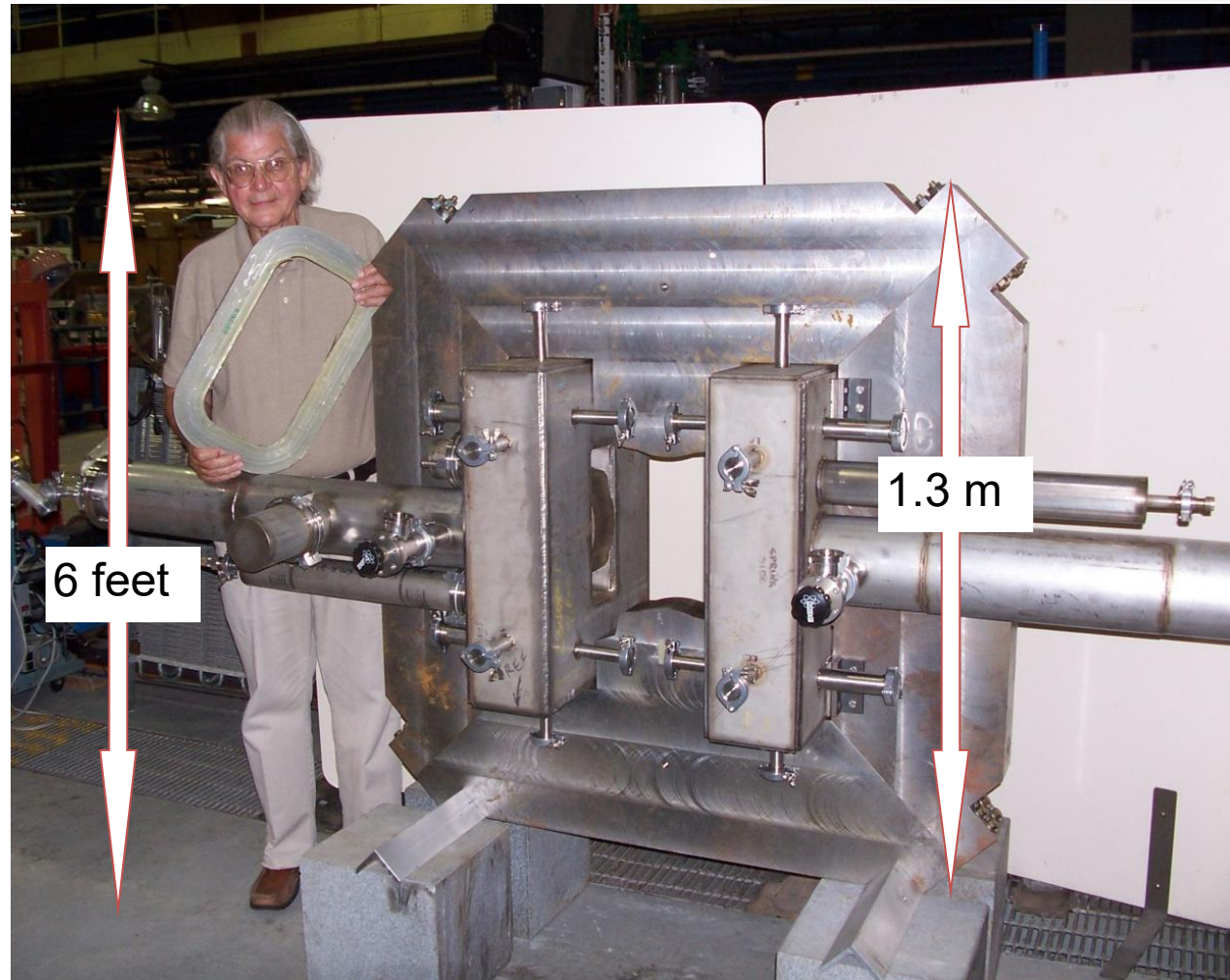

24 coils in the magnet

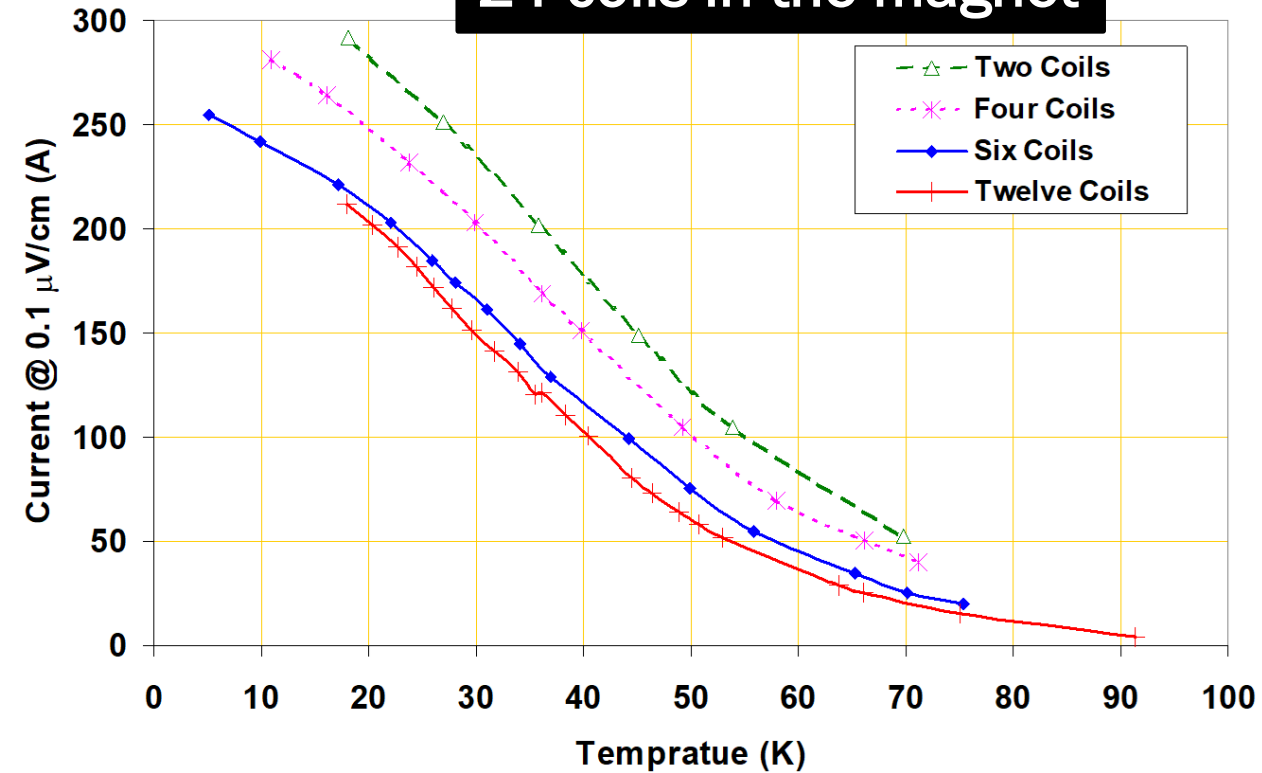

Whole magnet and setup is still available
Yoke can be removed in harmonics can be measured as a function of temperature

Cutout for Convenient Harmonic Measurements at Various Temperatures in a **cryo-cooled** magnet

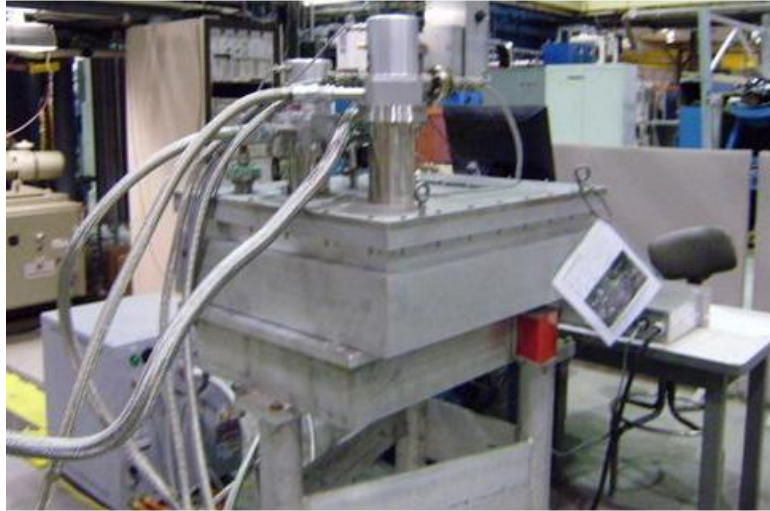

- Simple bolted cryostat for easy opening and installing HTS coils
- Cutout in the middle for harmonic measurements, HTS coil gets cold; measuring coil stays in warm region.
- Start cryo-cooler in the evening, coils ready for experiment in the morning.
- Available for low-cost measurements of harmonic at various temperatures without the need of liquid Helium.

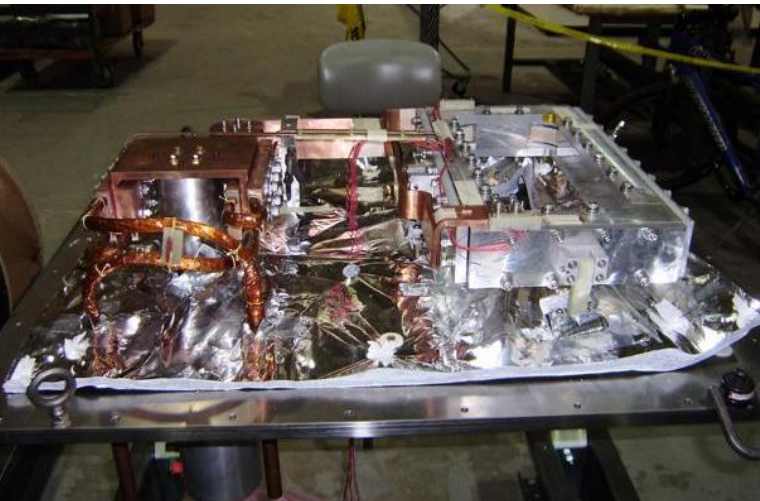

Adjustment of Temperature with Heaters (testing of FRIB R&D coils)

Stainless steel tape heaters for changing temperature of the coils by adding heat load on the outer plates (also for energy deposition experiments)

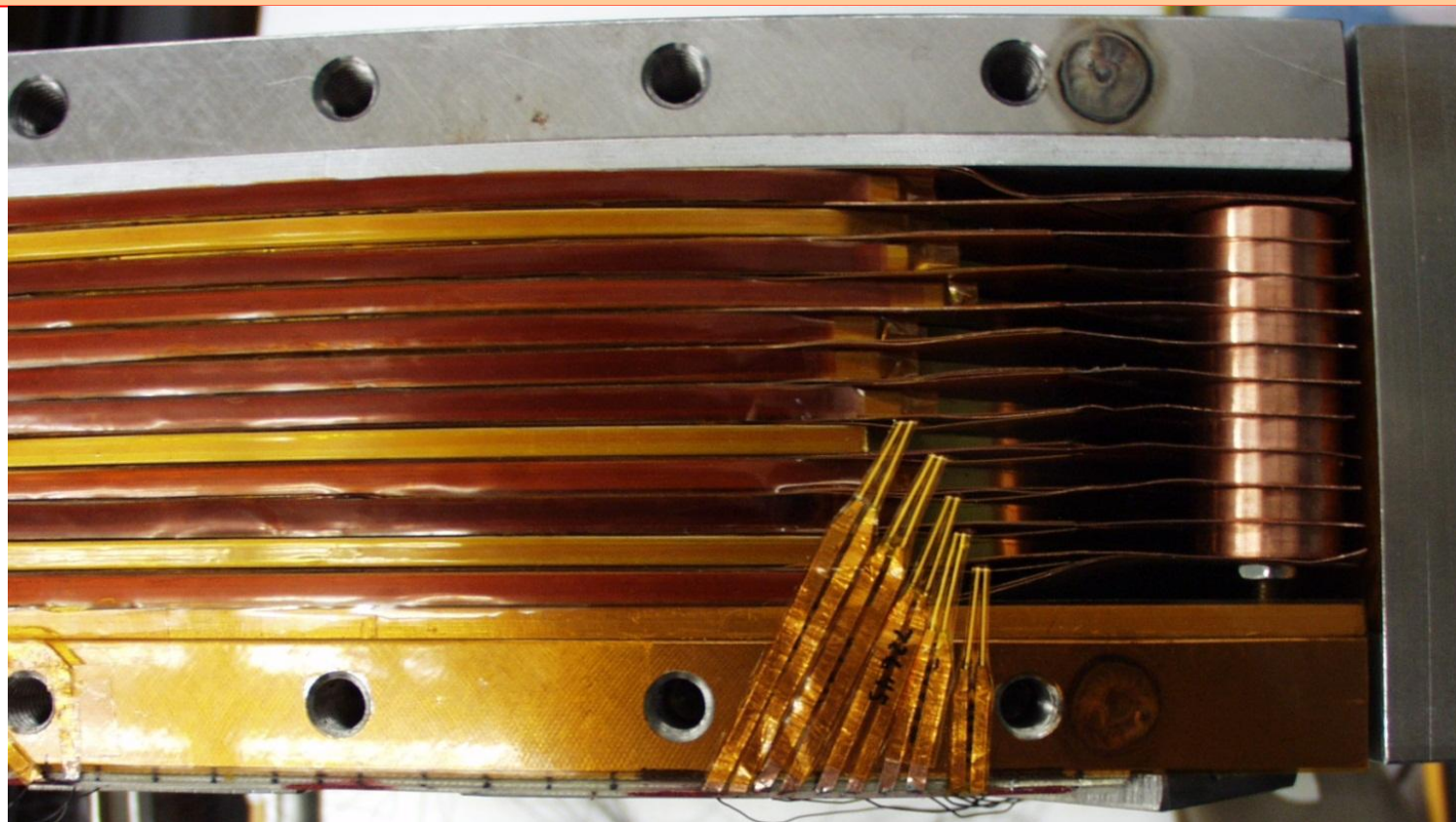

BNL High Temperature HTS R&D Program (to be primarily based on the large FRIB Coils)

Inventory of 100+ HTS coils can be used, if needed (including finding the limit of technology)

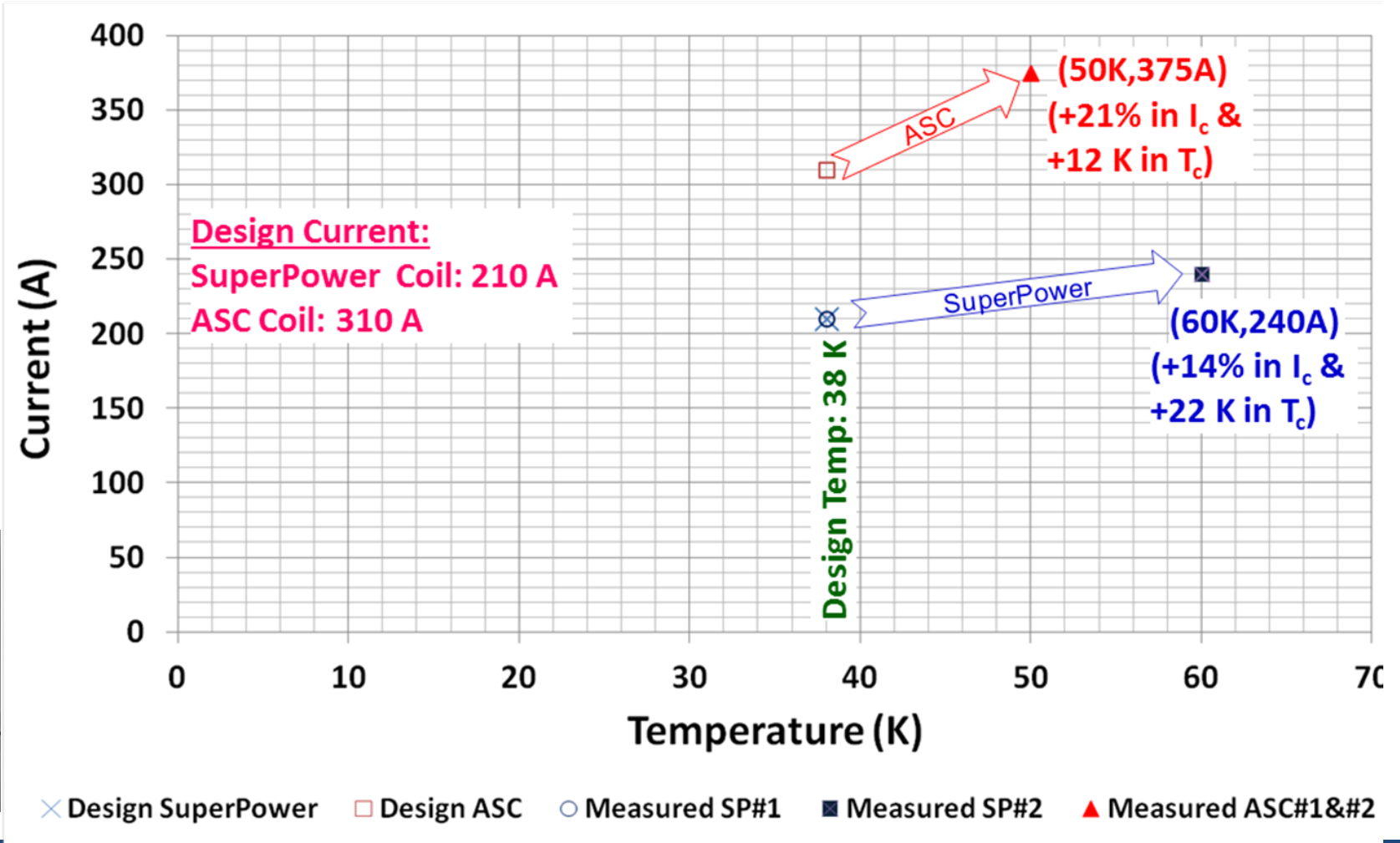
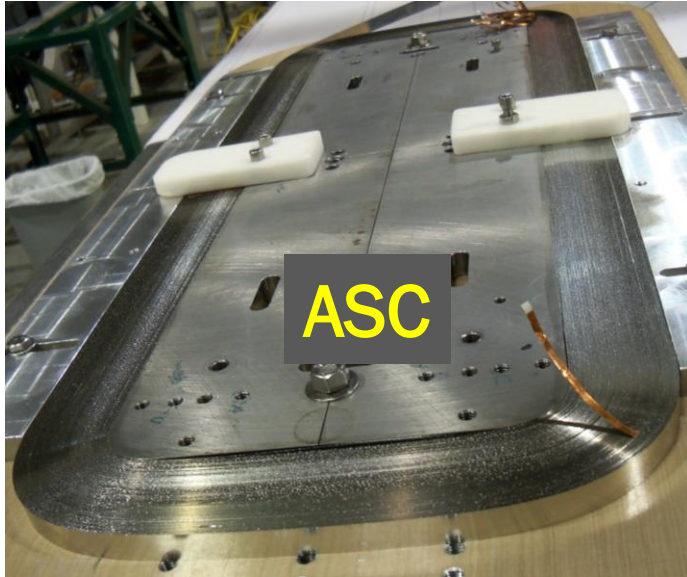

SUMMARY

- R&D program outlined here should provide initial guidance on the expected field harmonics based on measurements in HTS magnets that (a) machine physicists can use in designing accelerators, and (b) magnet scientists can use to test models, design of cables and magnets to reduce field harmonics.
- High temperature operation of HTS magnets offers an interesting option for accelerators. The proposed R&D program facilitate examining that option.
- This is the second part of a cost-effective program (first part was presented on Wednesday) for developing high field HTS and high field HTS/LTS hybrid magnet technology leverages existing large FRIB and other R&D coils.
- Collaborations and contributions are welcome from early-on, including input in shaping the technical program, goals and MDP milestones.



Extra Slides

Figure 3. Program structure with four dedicated areas.

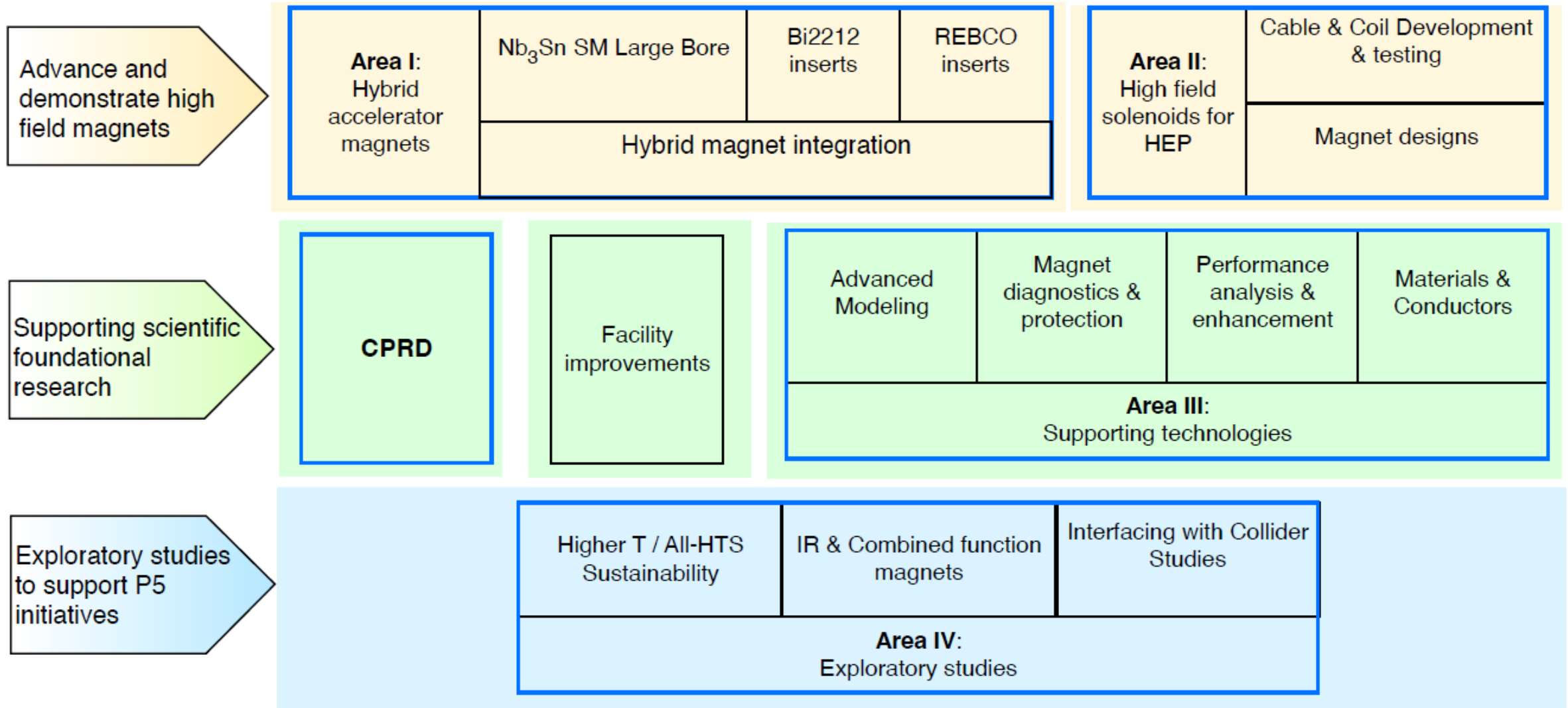

BNL is participating in all four areas of the MDP roadmap

Testing of HTS Solenoid (as a function of temperature)



Insert coil



Outsert coil

MT23 2013)

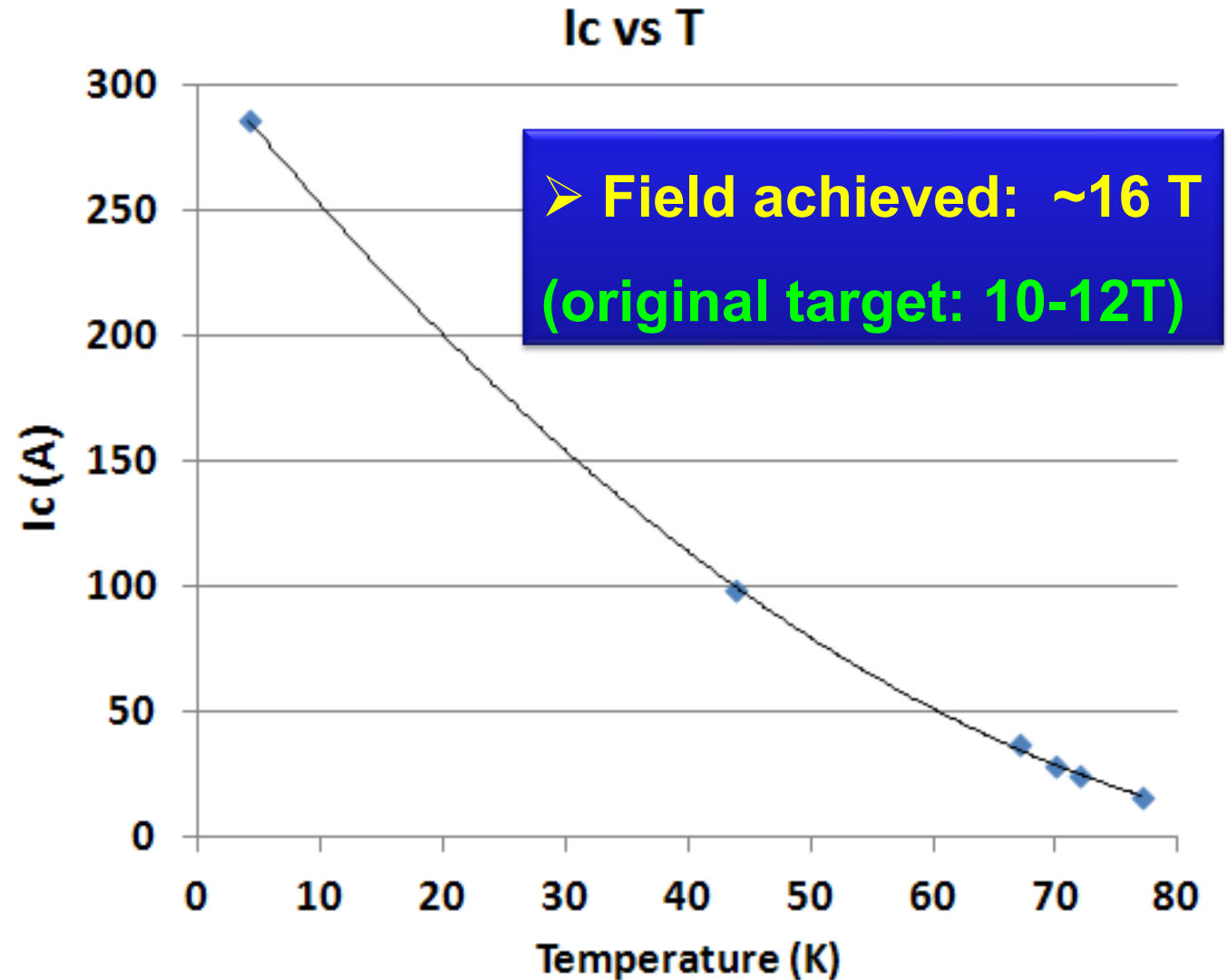



Cryo-cooler based structure

An easy to open & close simple Cryo-cooler based structure

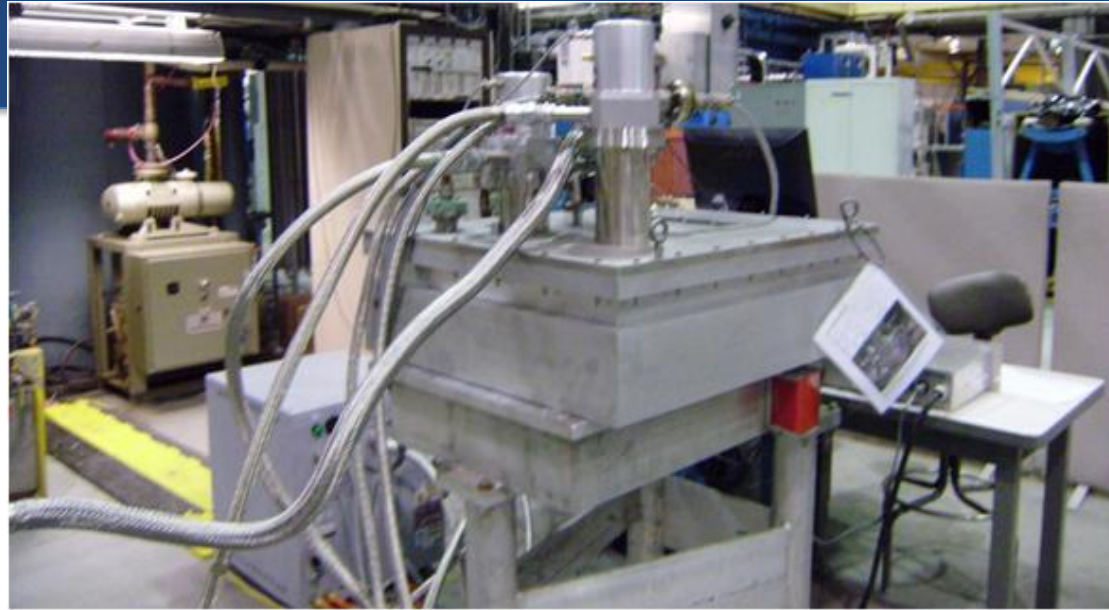

Up to six coils were tested in various configurations.

Cutout in the middle for warm iron or other warm

- **Coils reached <math><40\text{ K}</math> (goal was 40-50 K) measurements.**
- **Cryo-coolers turned-on at 5 pm and left unattended. Coils reached the desired temperature at 8:30 am next day.**
- **Experiment starts early morning (saving in cost & time).**
- **Good test bed for HTS coil technology – No Helium, no personnel, turn on cryo-cooler the evening before and start the actual experiment in the morning...**

HTS Coil Test @48K

(reached overnight with cryocoolers)

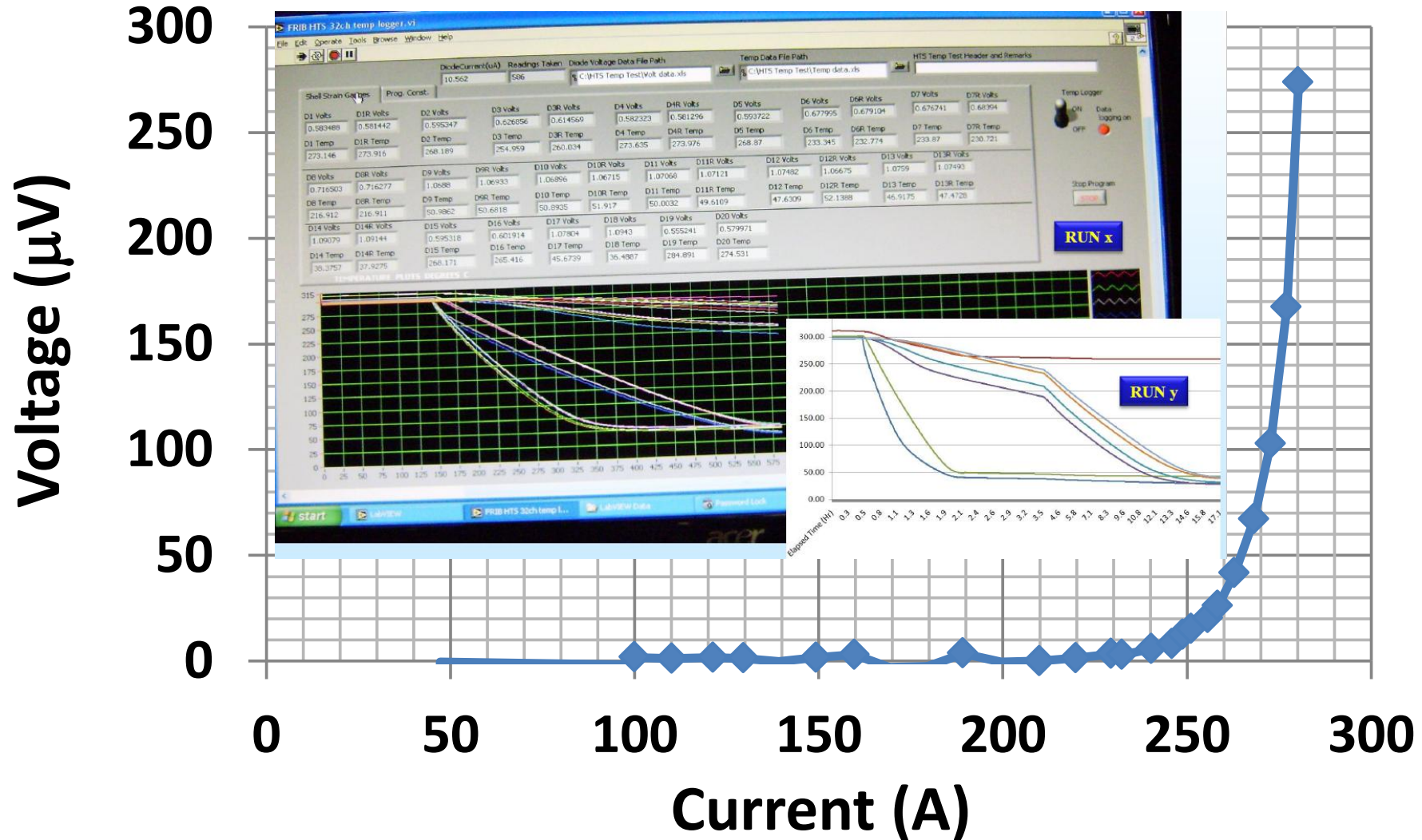
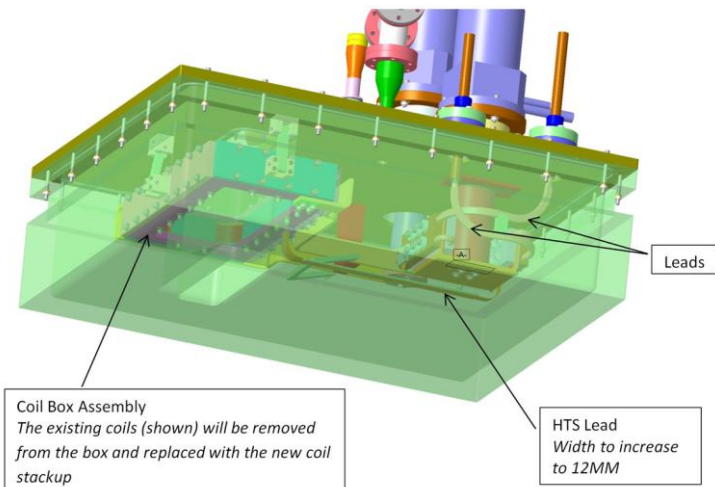
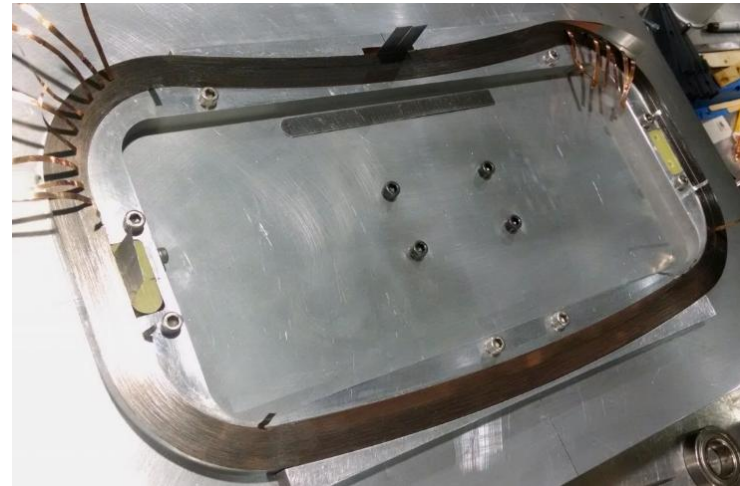

Quench studies with a large number of expensive HTS coils leftover from the previous R&D programs

(No fear of destroying them for a “burn to learn” approach)

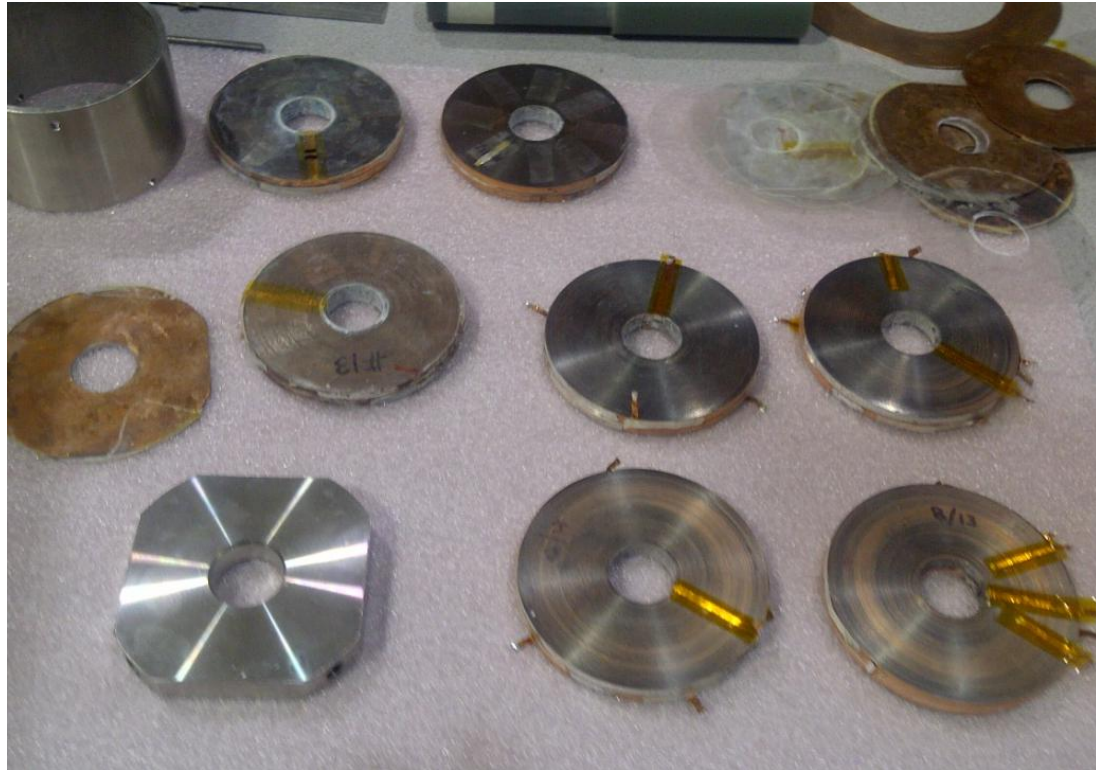

Continue development of BNL's Advanced Quench Protection Electronics

More background information at:

- <https://wpw.bnl.gov/rgupta/hts-magnet-program/>
- <https://wpw.bnl.gov/rgupta/common-coil-design/>
- <https://wpw.bnl.gov/rgupta/cctf/>